

**FLOW CHART**

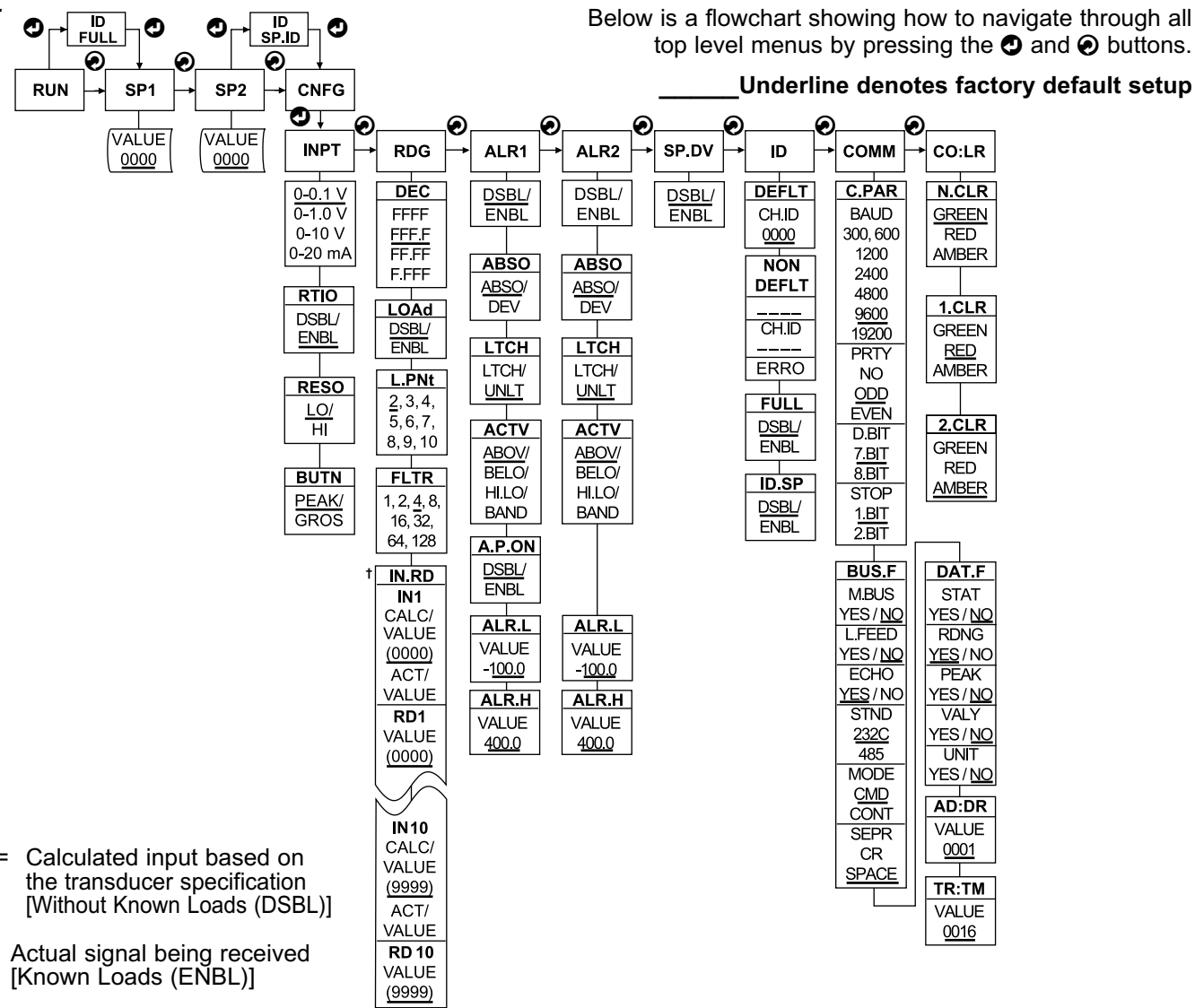

Below is a flowchart showing how to navigate through all top level menus by pressing the and buttons.

Underline denotes factory default setup

†Where:  
CALC/VALUE = Calculated input based on the transducer specification [Without Known Loads (DSBL)]

ACT/VALUE = Actual signal being received [Known Loads (ENBL)]

**READING CONFIGURATION SETUP (operation example)**

Below is a flowchart showing how to navigate through the submenus of the Reading Configuration menu item by pressing the front buttons.

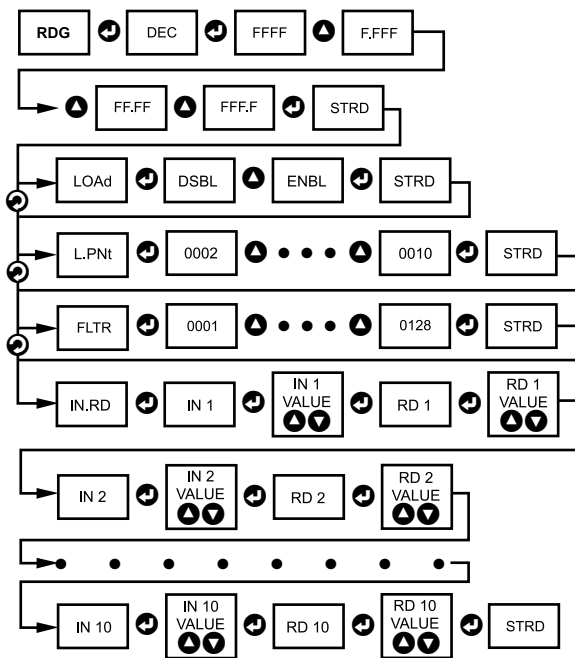

**DISPLAY COLOR SETUP (examples)**

**Example 1:**  
Alarm setup: Absolute, Above, Alarm 2 HI Value "ALR.H" =200, Alarm 1 HI Value "ALR.H"=400  
Color Display setup: Normal Color "N.CLR"=Green, Alarm 1 Color "1.CLR"=Amber, Alarm 2 Color "2.CLR"=Red

Display colors change sequences:

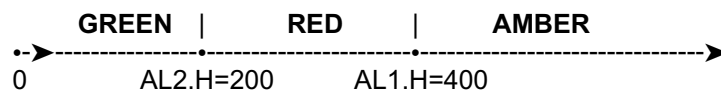

**Example 2:**  
Set Point 1: 200  
Set Point 2: 200  
Alarm 1 setup: Deviation, Band, "ALR.H" = 20  
Alarm 2 setup: Deviation, Hi/Low, "ALR.H" = 10", "ALR.L" = 5"  
Color Display setup: "N.CLR"=Green, "1.CLR"=Amber, "2.CLR"=Red

Display colors change sequences:



**SPECIFICATION**

**Accuracy:** 0.03% rdg.  
**Resolution:** 10 / 1 µV process  
**Linearization Points:** 10 points  
**Temperature Stability:** 50 ppm/°C process  
**Display:** 4-digit, 9-segment LED, 21 mm (0.83") with red, green and amber programmable colors  
**Input Types:** Analog Voltage and Current  
**Voltage:** 0 to 100 mV, 0 to 1 V (±100 mV), 0 to 10 Vdc  
**Input Impedance:** 10 MΩ for 100 mV, 1 MΩ for 1 or 10 Vdc  
**Current:** 0 to 20 mA (5 Ω load)

**Output 1':** Relay 250 Vac @ 3 A Resistive Load, SSR, Pulse  
**Output 2':** Relay 250 Vac @ 3 A Resistive Load, SSR, Pulse  
† Only with -AL Limit Alarm option  
**Options: Communication** RS-232 / RS-485 or 10BaseT or  
**Excitation:** 5 Vdc @ 40 mA, 10 Vdc @ 60 mA  
Exc. not available for Low Power Option  
**Line Voltage/Power:** 90 - 240 Vac ±10%, 50 - 400 Hz\*, or 110-375 Vdc, 4W for single display; 5W for dual display  
\* No CE compliance above 60 Hz  
**Low Voltage Power Option:** 12 - 36 Vdc, 3 W\*\* for single display, 20 - 36 Vdc, 4 W\*\* for dual display  
\*\* Units can be powered safely with 24 Vdc but No Certification for CE/UL are claimed.  
**Dimensions:** 48 H x 96 W x 127 D mm (1.89 x 3.78 x 5")  
**Weight:** 295 g (0.65 lb)  
**Approvals:** UL, C-UL, CE per EN61010-1:2001

**WARNING:** These products are not designed for use in, and should not be used for, patient-connected applications.

This device is marked with the international caution symbol. It is important to read the Setup Guide before installing or commissioning this device, as the guide contains important information relating to safety and EMC.

It is the policy of NEWPORT to comply with all worldwide safety and EMC/EMI regulations that apply. NEWPORT is constantly pursuing certification of its products to the European New Approach Directives. NEWPORT will add the CE mark to every appropriate device upon certification.

The information contained in this document is believed to be correct, but NEWPORT Electronics, Inc. accepts no liability for any errors it contains, and reserves the right to alter specifications without notice.

**TRADEMARK NOTICE:**

**NEWPORT**, **NEWPORT**, **newportUS.com**, and the "Meter Bezel Design" are Trademarks of NEWPORT ELECTRONICS, INC'

**WARRANTY/DISCLAIMER**

NEWPORT Electronics, Inc. warrants this unit to be free of defects in materials and workmanship for a period of one (1) year from the date of purchase. In addition to NEWPORT's standard warranty period, NEWPORT Electronics will extend the warranty period for four (4) additional years if the warranty card enclosed with each instrument is returned to NEWPORT.

If the unit malfunctions, it must be returned to the factory for evaluation. NEWPORT's Customer Service Department will issue an Authorized Return (AR) number immediately upon phone or written request. Upon examination by NEWPORT, if the unit is found to be defective, it will be repaired or replaced at no charge. NEWPORT's WARRANTY does not apply to defects resulting from any action of the purchaser, including but not limited to mishandling, improper interfacing, operation outside of design limits, improper repair, or unauthorized modification. This WARRANTY is VOID if the unit shows evidence of having been tampered with or shows evidence of having been damaged as a result of excessive corrosion or current, heat, moisture or vibration; improper specification; misapplication; misuse or other operating conditions outside of NEWPORT's control. Components which wear are not warranted, including but not limited to contact points, fuses, and triacs.

NEWPORT is pleased to offer suggestions on the use of its various products. However, NEWPORT neither assumes responsibility for any omissions or errors nor assumes liability for any damages that result from the use of its products in accordance with information provided by NEWPORT, either verbal or written. NEWPORT warrants only that the parts manufactured by it will be as specified and free of defects.

NEWPORT MAKES NO OTHER WARRANTIES OR REPRESENTATIONS OF ANY KIND WHATSOEVER, EXPRESS OR IMPLIED, EXCEPT THAT OF TITLE, AND ALL IMPLIED WARRANTIES INCLUDING ANY WARRANTY OF MERCHANTABILITY AND FITNESS FOR A PARTICULAR PURPOSE ARE HEREBY DISCLAIMED.

**LIMITATION OF LIABILITY:** The remedies of purchaser set forth herein are exclusive, and the total liability of NEWPORT with respect to this order, whether based on contract, warranty, negligence, indemnification, strict liability or otherwise, shall not exceed the purchase price of the component upon which liability is based. In no event shall NEWPORT be liable for consequential, incidental or special damages.

**CONDITIONS:** Equipment sold by NEWPORT is not intended to be used, nor shall it be used: (1) as a "Basic Component" under 10 CFR 21 (NRC), used in or with any nuclear installation or activity; or (2) in medical applications or used on humans. Should any Product(s) be used in or with any nuclear installation or activity, medical application, or used on humans, or misused in any way, NEWPORT assumes no responsibility as set forth in our basic WARRANTY/DISCLAIMER language, and, additionally purchaser will indemnify NEWPORT and hold NEWPORT harmless from any liability or damage whatsoever arising out of the use of the Product(s) in such a manner.

**RETURN REQUEST/INQUIRIES**

Direct all warranty and repair requests/inquiries to the NEWPORT Customer Service Department. BEFORE RETURNING ANY PRODUCT(S) TO NEWPORT, PURCHASER MUST OBTAIN AN AUTHORIZED RETURN (AR) NUMBER FROM NEWPORT'S CUSTOMER SERVICE DEPARTMENT (IN ORDER TO AVOID PROCESSING DELAYS). The assigned AR number should then be marked on the outside of the return package and on any correspondence.

The purchaser is responsible for shipping charges, freight, insurance and proper packaging to prevent breakage in transit.

FOR **WARRANTY** RETURNS, please consult NEWPORT for current repair BEFORE contacting NEWPORT:

1. Purchase Order number under which the product was PURCHASED,
2. Model and serial number of the product under warranty, and
3. Repair instructions and/or specific problems relative to the product.

FOR **NON-WARRANTY** REPAIRS, have the following information available charges. Have the following information available BEFORE contacting NEWPORT:

1. Purchase Order number to cover the COST the repair,
2. Model and serial number of product, and
3. Repair instructions and/or specific problems relative to the product.

NEWPORT's policy is to make running changes, not model changes, whenever an improvement is possible. This affords our customers the latest in technology and engineering.

NEWPORT is a registered trademark of NEWPORT Electronics, Inc.

© Copyright 2006 NEWPORT Electronics, Inc. All rights reserved.

This document may not be copied, photocopied, reproduced, translated, or reduced to any electronic medium or machine-readable form, in whole or in part, without the prior written consent of NEWPORT Electronics, Inc.

**PATENT NOTICE:** This product is covered by one or more of the following patents: U.S. Pat. No. Des. 336,895; 5,274,577; 6,243,021 / Canada 2052599; 2052600 / Italy 1249456; 1250938 / France Brevet No. 91 12756 / Spain 2039150; 2048066 / UK Patent No. GB2 249 837; GB2 248 954 / Germany DE 41 34388 C2. The is a Trademark of OMEGA Engineering, Inc. USED UNDER LICENSE. Other U.S. and International patents pending or applied for.



**Series**

**Process/Strain Gauge  
iS8 - Monitor  
iS8-AL - Limit Alarm**

For immediate technical or application assistance please call:

**1-800-6397678®  
1-800-NEWPORT**

Newport Electronics, Inc.  
2229 South Yale Street • Santa Ana, CA • 92704 • U.S.A.  
TEL: (714) 540-4914 • FAX: (203) 968-7311  
Toll Free: 1-800-639-7678 • www.newportUS.com • e-mail: info@newportUS.com  
ISO 9001 Certified

Newport Technologies, Inc.  
976 Bergar • Laval (Quebec) • H7L 5A1 • Canada  
TEL: (514) 335-3183 • FAX: (514) 856-6886  
Toll Free: 1-800-639-7678 • www.newport.ca • e-mail: info@newport.ca

Newport Electronics, Ltd.  
One Omega Drive • River Bend Technology Centre  
Northbank, Irlam • Manchester M44 5BD • United Kingdom  
Tel: +44 161 777 6611 • FAX: +44 161 777 6622  
Toll Free: 0800 488 488 • www.newportuk.co.uk • e-mail: sales@newportuk.co.uk

Newport Electronics B.V. - Benelux  
TEL: +31 20 3472121 • FAX: +31 20 6434643  
Toll Free: 0800 0993344 • www.newport.nl • e-mail: info@newport.nl

Newport Electronics spol s.r.o.  
Frystaska 184, 733 01 Karviná • Czech Republic  
TEL: +420 59 6311899 • FAX: +420 59 6311114  
Toll Free: 0800-1-66342 • www.newport.cz • e-mail: info@newport.cz

Newport Electronics GmbH  
Daimlerstrasse 26 • D-75392 Deckenpfronn • Germany  
TEL: 49 7056 9398-0 • FAX: 49 7056 9398-29  
Toll Free: 0800 / 6397678 • www.newport.de • e-mail: sales@newport.de

Newport Electronique S.A.R.L. - France  
TEL: +33 1 61 37 29 00 • FAX: +33 1 30 57 54 27  
Toll Free: 0800 466 342 • www.newport.fr • e-mail: sales@newport.fr

Mexico and Latin America  
FAX: 001 (203) 359-7807  
TEL En Español: 001 (203) 359-7803

**NEWPORTnet™ On-Line Service** **Internet e-mail**  
www.newportUS.com info@newportUS.com

**NEWPORT** Electronics, Inc.



This Quick Start Reference provides information on setting up your instrument for basic operation. The latest complete Communication and Operational Manual as well as free Software and ActiveX Controls are available at [www.newportUS.com/i](http://www.newportUS.com/i) or on the CD-ROM enclosed with your shipment.

### SAFETY CONSIDERATION



This device is marked with the international Caution symbol.

The instrument is a panel mount device protected in accordance with EN 61010-1:2001, electrical safety requirements for electrical equipment for measurement, control and laboratory. Remember that the unit has no power-on switch. Building installation should include a switch or circuit-breaker that must be compliant to IEC 947-1 and 947-3.

### SAFETY:

- Do not exceed voltage rating on the label located on the top of the instrument housing.
- Always disconnect power before changing signal and power connections.
- Do not use this instrument on a work bench without its case for safety reasons.
- Do not operate this instrument in flammable or explosive atmospheres.
- Do not expose this instrument to rain or moisture.

### EMC:

- Whenever EMC is an issue, always use shielded cables.
- Never run signal and power wires in the same conduit.
- Use signal wire connections with twisted-pair cables.
- Install Ferrite Bead(s) on signal wire close to the instrument if EMC problems persist.

### MOUNTING

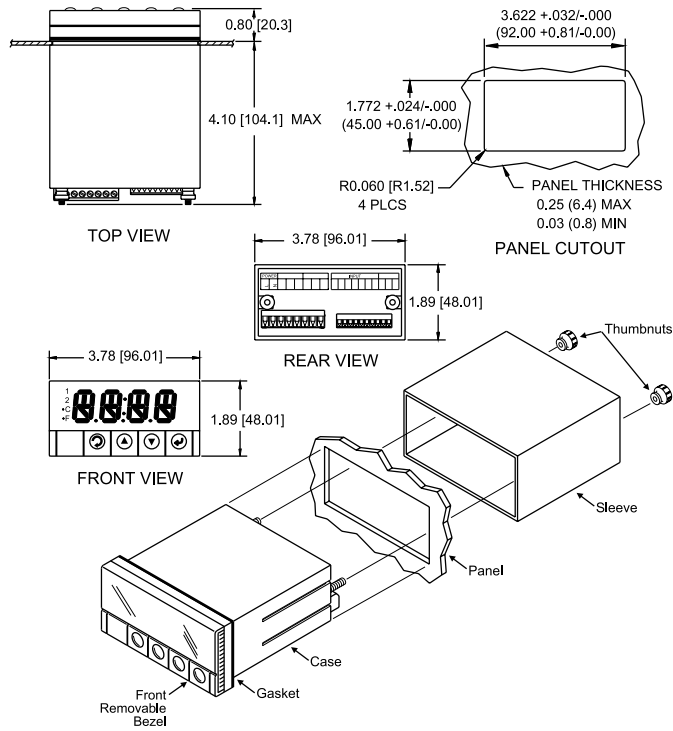

### Panel Mounting Instruction:

- Using the dimensions from the panel cutout diagram shown above, cut an opening in the panel.
- Remove sleeve from the rear of the case by removing thumbnuts.
- Insert the unit into the opening from the front of the panel, so the gasket seals between the bezel and the front of the panel.
- Slip the sleeve over the rear of the case.
- Tighten the thumbnuts to hold the unit firmly in the panel.

### Disassembly Instruction:

If necessary, the board assembly may be removed from the front of the case housing.



**Warning: Disconnect all ac power from the unit before proceeding.**

- Remove the board assembly from the case by pulling at the sides of the bezel.
- The bezel along with the board assembly will unlatch from the case housing.

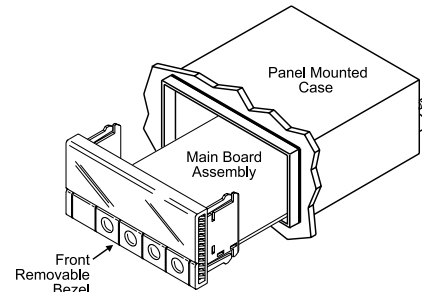

### WIRING

Wire the instrument according to the figure shown below.

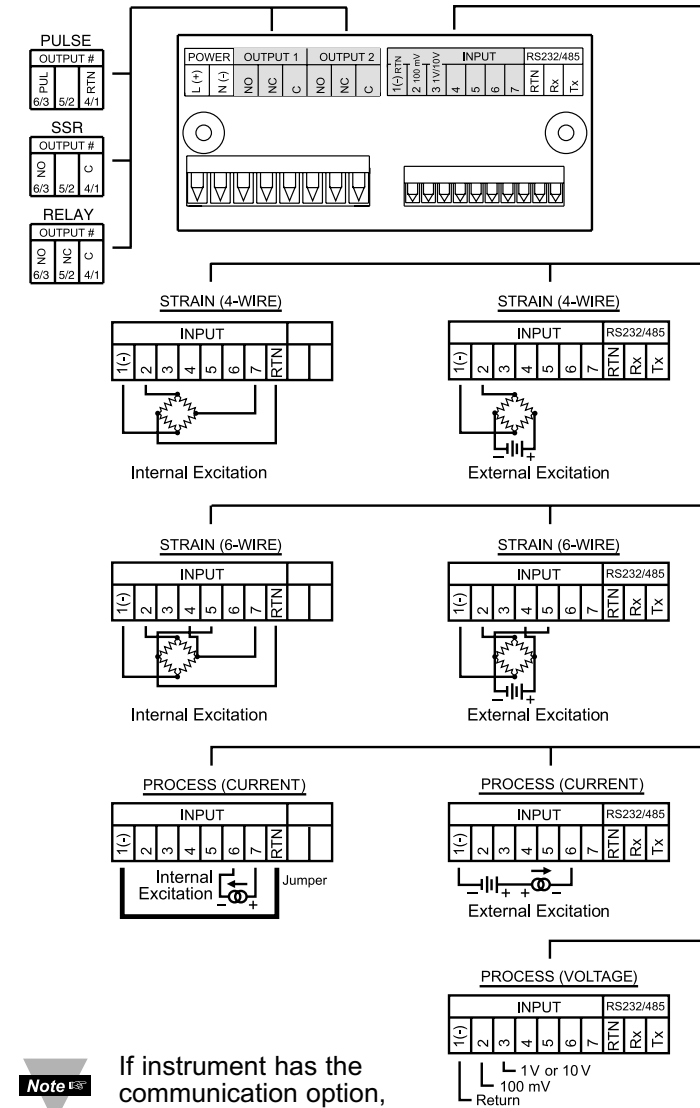

If instrument has the communication option, the internal excitation is not available. Use external excitation to power your transducer.



**Warning: Do not connect ac power to your device until you have completed all input and output connections. This device must only be installed by a specially trained electrician with corresponding qualifications. Failure to follow all instructions and warnings may result in injury!**

Connect the main power connections as shown in the figure below.

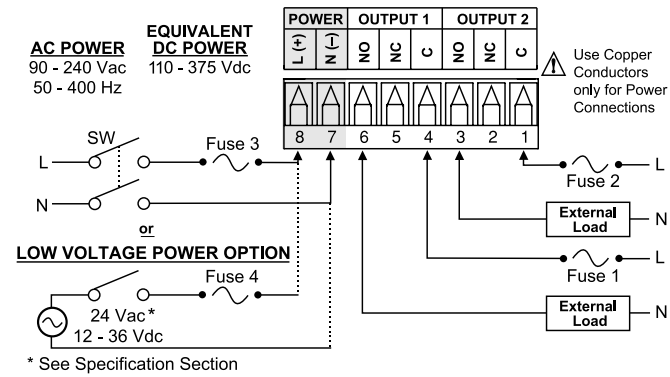

FUSE	Connector	Output Type	For 115Vac	For 230Vac	DC
FUSE 1	Output 1	Relay	3 A(T)	3 A(T)	-
FUSE 2	Output 2	Relay	3 A(T)	3 A(T)	-
FUSE 3	Power	N/A	100 mA(T)	100 mA(T)	100 mA(T)
FUSE 4	Power	N/A	N/A	N/A	400 mA(T)



Output 1 and 2 are for -AL Limit Alarm Option only.

### CONFIGURATION

Button Functions in Configuration Mode

	<ul style="list-style-type: none"> <li>To enter the Menu, the user must first press .</li> <li>Use this button to advance/navigate to the next menu item. The user can navigate through all the top level menus by pressing .</li> <li>While a parameter is being modified, press  to escape without saving the parameter.</li> </ul>
	<ul style="list-style-type: none"> <li>Press the up  button to scroll through "flashing" selections. When a numerical value is displayed press this key to increase value of a parameter that is currently being modified.</li> <li>Holding the  button down for approximately 3 seconds will speed up the rate at which the setpoint value is incremented.</li> <li>In the Run Mode pressing  causes the display to flash the PEAK or GROSS value – press again to return to the Run Mode.</li> </ul>
	<ul style="list-style-type: none"> <li>Press the down  button to go back to a previous Top Level Menu item.</li> <li>Press this button twice to reset the controller to the Run Mode.</li> <li>When a numerical value is flashing (except setpoint value) press  to scroll digits from left to right allowing the user to select the desired digit to modify.</li> <li>When a setpoint value is displayed press  to decrease value of a setpoint that is currently being modified. Holding the  button down for approximately 3 seconds will speed up the rate at which the setpoint value is decremented.</li> <li>In the Run Mode pressing  causes the display to flash TARE value to tare your reading (zeroing).</li> </ul>
	<ul style="list-style-type: none"> <li>Press the enter  button to access the submenus from a Top Level Menu item.</li> <li>Press  to store a submenu selection or after entering a value — the display will flash a <b>SEEd</b> message to confirm your selection.</li> <li>To reset flashing PEAK or GROSS press .</li> <li>In the Run Mode, press  twice to enable Standby Mode with flashing <b>SEbY</b>.</li> </ul>



Reset: Except for Alarms, modifying any settings of the menu configuration will reset the controller prior to resuming Run Mode.

### DISPLAY ABBREVIATIONS

SP1	Set Point 1 Value	SP2	Set Point 2 Value
CNFG	Configuration Menu	INPt	
INPt	Input Type (range)	0 - 0.1	100 mV Input Voltage
0 - 1.0	1 V Input Voltage	0 - 10	10 V Input Voltage
0 - 20	20 mA Input Current		
Rtio	Ratiometric Operation	RESO	Display Resolution
bUtN	Button Peak/Gross	PEAK	Peak Value
GROS	Gross Value		
RdG	Reading Configuration		
dEC	Decimal Point	F.FFF	Decimal Point Position
		..FFFF	
LOAD	Input Load	EnbL	Scaling with Known Loads (Actual Value)
DSbL	Scaling without Known Loads (Calculated Value)	L.PNt	Linearization Points
0002..	Number of Linearization Points	FLtR	Filter Constant
..0010			
0001..	Filter Constant Value	IN.Rd	Input/Reading Scale and Offset Menu
..0128			
IN 1	Input 1	Rd 1	Reading 1
IN 2	Input 2	Rd 2	Reading 2
....		....	
IN 10	Input 10	Rd 10	Reading 10
ALR1	Alarm 1 Menu	AbSo	Absolute Mode
dEV	Deviation Mode	LtcH	Latched Mode
UNLt	Unlatched Mode	Ct.CL	Contact Closure
N.o.	Normally Open	N.c.	Normally Closed
ActV	Active Type	AbOV	Active Above
bELo	Active Below	Hi.Lo	Above High/Below Low
bAnd	Above or Below Band	A.P.oN	Alarm Enable/Disable at Power On
ALR.L	Alarm Low Value	ALR.H	Alarm High Value
ALR.2	Alarm 2 Menu		
SP.dN	Set Point Deviation		
Id	ID Code Menu	CH.Id	Change ID Code
FULL	Full ID	SP.Id	Set Point ID
COMM	Communication Option*	NONE	Communication is Not Installed
C.PAR	Communication Parameters	baUD	Baud Rate
PRtY	Parity	odd	Odd
EVEN	Even	No	No
dAtA	Data Bit	7.bit	7 Data Bit
8.bit	8 Data Bit	StOP	Stop Bit
1.bit	1 Data Bit	2.bit	2 Stop Bit
bus.F	Bus Format	M.bus	Modbus Protocol
LF	Line Feed	ECHO	Echo
StNd	Communication Standard	232C	RS-232
485	RS-485	ModE	Data Flow Mode
CMD	Command Mode	CoNt	Continuous Mode
SEPR	Data Separation Character	SPCE	Space
cR	Carriage Return	dAt.F	Data Format
stAt	Alarm Status	RdNG	Transmit Reading Value
PEAK	Transmit Peak Value	GROS	Transmit Gross Value
UNit	Units of Measurement	AddR	Multipoint Address
tR.tM	Transmit Color Selection		
COLR	Display Color Selection	N.CLR	Normal Color Display
1.CLR	Alarm 1 Color Display	2.CLR	Alarm 2 Color Display
REd	Display Color is Red	AMbR	Display Color is Amber
GRN	Display Color is Green		
dSbL	Disable	ENbL	Enable
ERRO	Error	+ OL	Input (+) Overload

\* For abbreviations of Communication Option see Communication Manual.