

FLOW CHART

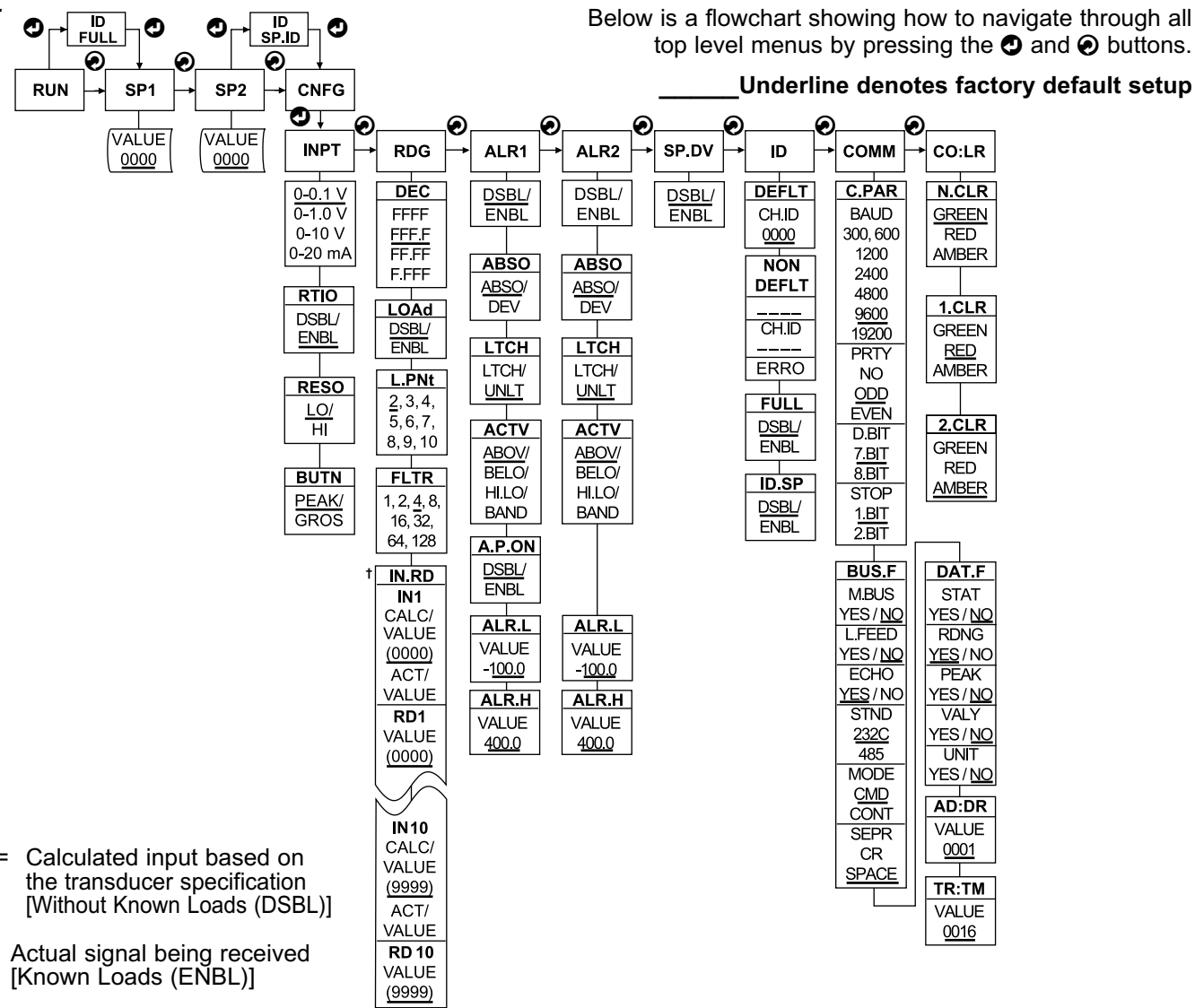

Below is a flowchart showing how to navigate through all top level menus by pressing the **↶** and **↷** buttons.

Underline denotes factory default setup

†Where:
 CALC/VALUE = Calculated input based on the transducer specification [Without Known Loads (DSBL)]
 ACT/VALUE = Actual signal being received [Known Loads (ENBL)]

READING CONFIGURATION SETUP (operation example)

Below is a flowchart showing how to navigate through the submenus of the Reading Configuration menu item by pressing the front buttons.

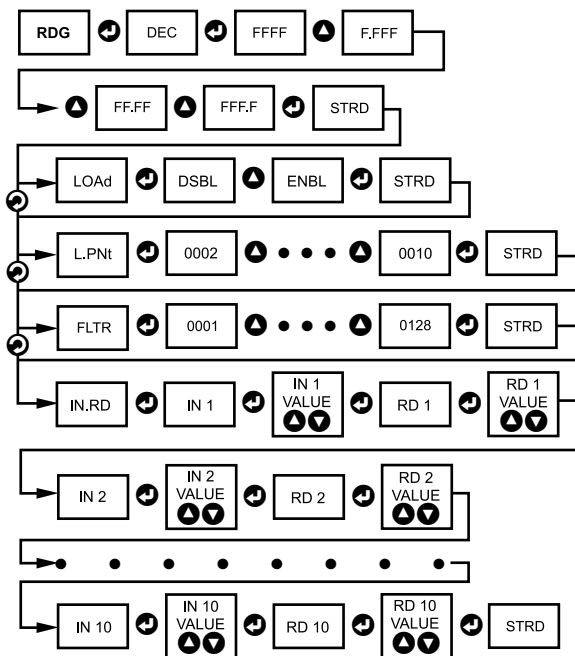

DISPLAY COLOR SETUP (examples)

Example 1:
 Alarm setup: Absolute, Above, Alarm 2 HI Value "ALR.H" =200, Alarm 1 HI Value "ALR.H"=400
 Color Display setup: Normal Color "N.CLR"=Green, Alarm 1 Color "1.CLR"=Amber, Alarm 2 Color "2.CLR"=Red

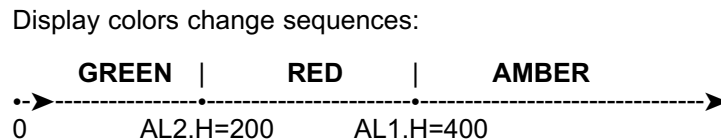

Example 2:
 Set Point 1: 200
 Set Point 2: 200
 Alarm 1 setup: Deviation, Band, "ALR.H" = 20
 Alarm 2 setup: Deviation, Hi/Low, "ALR.H = 10", "ALR.L = 5"
 Color Display setup: "N.CLR"=Green, "1.CLR"=Amber, "2.CLR"=Red

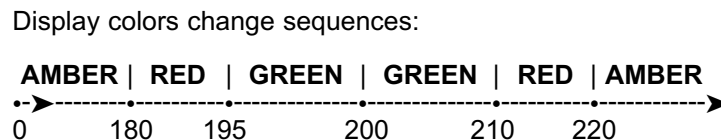

SPECIFICATION

Accuracy: 0.03% rdg.
Resolution: 10 / 1 µV process
Linearization Points: 10 points
Temperature Stability: 50 ppm/°C process
Display: 4-digit, 9-segment LED, 10.2 mm (0.40") with red, green and amber programmable colors
Input Types: Analog Voltage and Current
Voltage: 0 to 100 mV, 0 to 1 V (±100 mV), 0 to 10 Vdc
Input Impedance: 10 MΩ for 100 mV, 1 MΩ for 1 or 10 Vdc
Current: 0 to 20 mA (5 Ω load)
Output 1': Relay 250 Vac @ 3 A Resistive Load, SSR, Pulse
Output 2': Relay 250 Vac @ 3 A Resistive Load, SSR, Pulse
Options: Communication RS-232 / RS-485 or
Excitation: 5 Vdc @ 40 mA, 10 Vdc @ 60 mA
Line Voltage/Power: 90 - 240 Vac ±10%, 50 - 400 Hz*, or 110-375 Vdc, 4W for single display; 5W for dual display
Low Voltage Power Option: 12-36 Vdc, 3W** for single display; 20-36 Vdc, 4W** for dual display
Dimensions: 48 H x 48 W x 127 D mm (1.89 x 1.89 x 5")
Weight: 159 g (0.35 lb)
Approvals: UL, C-UL, CE per EN61010-1:2001

WARNING: These products are not designed for use in, and should not be used for, patient-connected applications.

This device is marked with the international caution symbol. It is important to read the Setup Guide before installing or commissioning this device, as the guide contains important information relating to safety and EMC.

It is the policy of NEWPORT to comply with all worldwide safety and EMC/EMI regulations that apply. NEWPORT is constantly pursuing certification of its products to the European New Approach Directives. NEWPORT will add the CE mark to every appropriate device upon certification.

The information contained in this document is believed to be correct, but NEWPORT Electronics, Inc. accepts no liability for any errors it contains, and reserves the right to alter specifications without notice.

TRADEMARK NOTICE: NEWPORT, NEWPORT, newportUS.com, and the "Meter Bezel Design" are Trademarks of NEWPORT ELECTRONICS, INC.

WARRANTY/DISCLAIMER

NEWPORT Electronics, Inc. warrants this unit to be free of defects in materials and workmanship for a period of one (1) year from the date of purchase. In addition to NEWPORT's standard warranty period, NEWPORT Electronics will extend the warranty period for four (4) additional years if the warranty card enclosed with each instrument is returned to NEWPORT.

If the unit malfunctions, it must be returned to the factory for evaluation. NEWPORT's Customer Service Department will issue an Authorized Return (AR) number immediately upon phone or written request. Upon examination by NEWPORT, if the unit is found to be defective, it will be repaired or replaced at no charge. NEWPORT's WARRANTY does not apply to defects resulting from any action of the purchaser, including but not limited to mishandling, improper interfacing, operation outside of design limits, improper repair, or unauthorized modification. This WARRANTY is VOID if the unit shows evidence of having been tampered with or shows evidence of having been damaged as a result of excessive corrosion or current, heat, moisture or vibration; improper specification; misapplication; misuse or other operating conditions outside of NEWPORT's control. Components which wear are not warranted, including but not limited to contact points, fuses, and triacs.

NEWPORT is pleased to offer suggestions on the use of its various products. However, NEWPORT neither assumes responsibility for any omissions or errors nor assumes liability for any damages that result from the use of its products in accordance with information provided by NEWPORT, either verbal or written. NEWPORT warrants only that the parts manufactured by it will be as specified and free of defects.

NEWPORT MAKES NO OTHER WARRANTIES OR REPRESENTATIONS OF ANY KIND WHATSOEVER, EXPRESS OR IMPLIED, EXCEPT THAT OF TITLE, AND ALL IMPLIED WARRANTIES INCLUDING ANY WARRANTY OF MERCHANTABILITY AND FITNESS FOR A PARTICULAR PURPOSE ARE HEREBY DISCLAIMED.

LIMITATION OF LIABILITY: The remedies of purchaser set forth herein are exclusive, and the total liability of NEWPORT with respect to this order, whether based on contract, warranty, negligence, indemnification, strict liability or otherwise, shall not exceed the purchase price of the component upon which liability is based. In no event shall NEWPORT be liable for consequential, incidental or special damages.

CONDITIONS: Equipment sold by NEWPORT is not intended to be used, nor shall it be used: (1) as a "Basic Component" under 10 CFR 21 (NRC), used in or with any nuclear installation or activity; or (2) in medical applications or used on humans. Should any Product(s) be used in or with any nuclear installation or activity, medical application, or used on humans, or misused in any way, NEWPORT assumes no responsibility as set forth in our basic WARRANTY/DISCLAIMER language, and, additionally purchaser will indemnify NEWPORT and hold NEWPORT harmless from any liability or damage whatsoever arising out of the use of the Product(s) in such a manner.

RETURN REQUEST/INQUIRIES

Direct all warranty and repair requests/inquiries to the NEWPORT Customer Service Department. BEFORE RETURNING ANY PRODUCT(S) TO NEWPORT, PURCHASER MUST OBTAIN AN AUTHORIZED RETURN (AR) NUMBER FROM NEWPORT'S CUSTOMER SERVICE DEPARTMENT (IN ORDER TO AVOID PROCESSING DELAYS). The assigned AR number should then be marked on the outside of the return package and on any correspondence.

The purchaser is responsible for shipping charges, freight, insurance and proper packaging to prevent breakage in transit.

FOR WARRANTY RETURNS, please consult NEWPORT for current repair BEFORE contacting NEWPORT:

- | | |
|---|--|
| <ol style="list-style-type: none"> Purchase Order number under which the product was PURCHASED, Model and serial number of the product under warranty, and Repair instructions and/or specific problems relative to the product. | <p>FOR NON-WARRANTY REPAIRS, have the following information available BEFORE contacting NEWPORT:</p> <ol style="list-style-type: none"> Purchase Order number to cover the COST the repair, Model and serial number of product, and Repair instructions and/or specific problems relative to the product. |
|---|--|

NEWPORT's policy is to make running changes, not model changes, whenever an improvement is possible. This affords our customers the latest in technology and engineering.

NEWPORT is a registered trademark of NEWPORT Electronics, Inc.
 © Copyright 2006 NEWPORT Electronics, Inc. All rights reserved.

This document may not be copied, photocopied, reproduced, translated, or reduced to any electronic medium or machine-readable form, in whole or in part, without the prior written consent of NEWPORT Electronics, Inc.

PATENT NOTICE: This product is covered by one or more of the following patents: U.S. Pat. No. Des. 336,895; 5,274,577; 6,243,021 / Canada 2052599; 2052600 / Italy 1249456; 1250938 / France Brevet No. 91 12756 / Spain 2039150; 2048066 / UK Patent No. GB2 249 837; GB2 248 954 / Germany DE 41 34398 C2. The is a Trademark of OMEGA Engineering, Inc. USED UNDER LICENSE. Other U.S. and International patents pending or applied for.

QUICK START



i/16 Series
Process / Strain Gauge Monitor / Limit Alarm (-AL)

For immediate technical or application assistance please call:

1-800-6397678
1-800-NEWPORT

Newport Electronics, Inc.
 2229 South Yale Street • Santa Ana, CA • 92704 • U.S.A.
 TEL: (714) 540-4914 • FAX: (203) 968-7311
 Toll Free: 1-800-639-7678 • www.newportUS.com • e-mail:info@newportUS.com
 ISO 9001 Certified

Newport Technologies, Inc.
 976 Bergar • Laval (Quebec) • H7L 5A1 • Canada
 TEL: (514) 335-3183 • FAX: (514) 856-6886
 Toll Free: 1-800-639-7678 • www.newport.ca • e-mail:info@newport.ca

Newport Electronics, Ltd.
 One Omega Drive • River Bend Technology Centre
 Northbank, Irlam • Manchester M44 5BD • United Kingdom
 Tel: +44 161 777 6611 • FAX: +44 161 777 6622
 Toll Free: 0800 488 488 • www.newportuk.co.uk • e-mail:sales@newportuk.co.uk

Newport Electronics spol s.r.o.
 Frystatska 184, 733 01 Karviná • Czech Republic
 TEL: +420 59 6311899 • FAX: +420 59 6311114
 Toll Free: 0800-1-66342 • www.newport.cz • e-mail: info@newport.cz

Newport Electronics GmbH
 Daimlerstrasse 26 • D-75392 Deckenpfronn • Germany
 TEL: 49 7056 9398-0 • FAX: 49 7056 9398-29
 Toll Free: 0800 / 6397678 • www.newport.de • e-mail: sales@newport.de

Mexico and Latin America
 FAX: 001 (203) 359-7807
 En Español: 001 (203) 359-7803

NEWPORTnet™ On-Line Service www.newportUS.com
Internet e-mail info@newportUS.com





This Quick Start Reference provides information on setting up your instrument for basic operation. The latest complete Communication and Operational Manual as well as free Software and ActiveX Controls are available at www.newportUS.com/i or on the CD-ROM enclosed with your shipment.

SAFETY CONSIDERATION



This device is marked with the international Caution symbol.

The instrument is a panel mount device protected in accordance with EN61010-1:2001. Remember that the unit has no power-on switch. Building installation should include a switch or circuit-breaker that must be compliant to IEC 947-1 and 947-3.

SAFETY:

- Do not exceed voltage rating on the label located on the top of the instrument housing.
- Always disconnect power before changing signal and power connections.
- Do not use this instrument on a work bench without its case for safety reasons.
- Do not operate this instrument in flammable or explosive atmospheres.
- Do not expose this instrument to rain or moisture.

EMC:

- Whenever EMC is an issue, always use shielded cables.
- Never run signal and power wires in the same conduit.
- Use signal wire connections with twisted-pair cables.
- Install Ferrite Bead(s) on signal wire close to the instrument if EMC problems persist.

MOUNTING

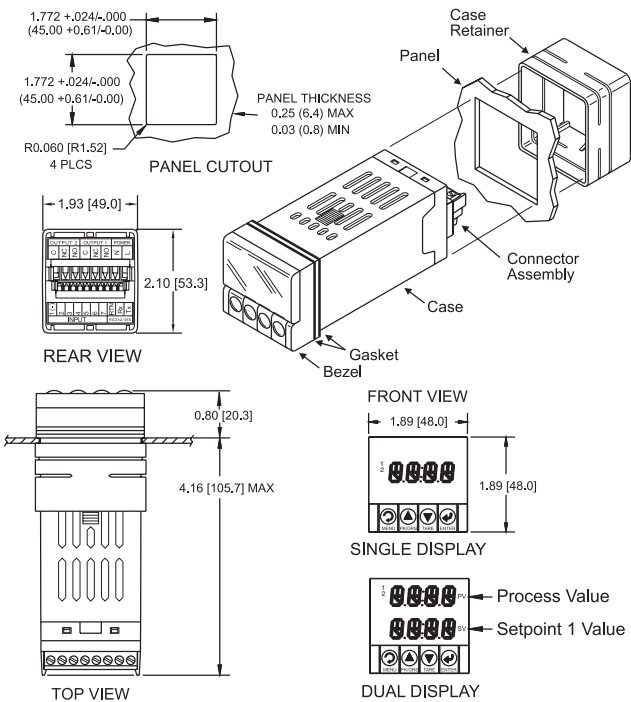

Panel Mounting Instruction:

- Using the dimensions from the panel cutout diagram shown above, cut an opening in the panel.
- Insert the unit into the opening from the front of the panel, so the gasket seals between the bezel and the front of the panel.
- Slide the retainer over the rear of the case and tighten against the backside of the panel.

Disassembly Instruction:

If necessary, the unit may be removed from the panel and opened.



Warning: Disconnect all ac power from the unit before proceeding.

- Remove all wiring connections from the rear of the meter. To remove power and input connectors squeeze top and bottom of the case near the connector site for release, then pull connectors from the meter.
- To remove meter from the case, squeeze top and bottom of the bezel to release, then pull from case.

WIRING

Wire the instrument according to the figure shown below.



Warning: Do not connect ac power to your device until you have completed all input and output connections. This device must only be installed by a specially trained electrician with corresponding qualifications. Failure to follow all instructions and warnings may result in injury!

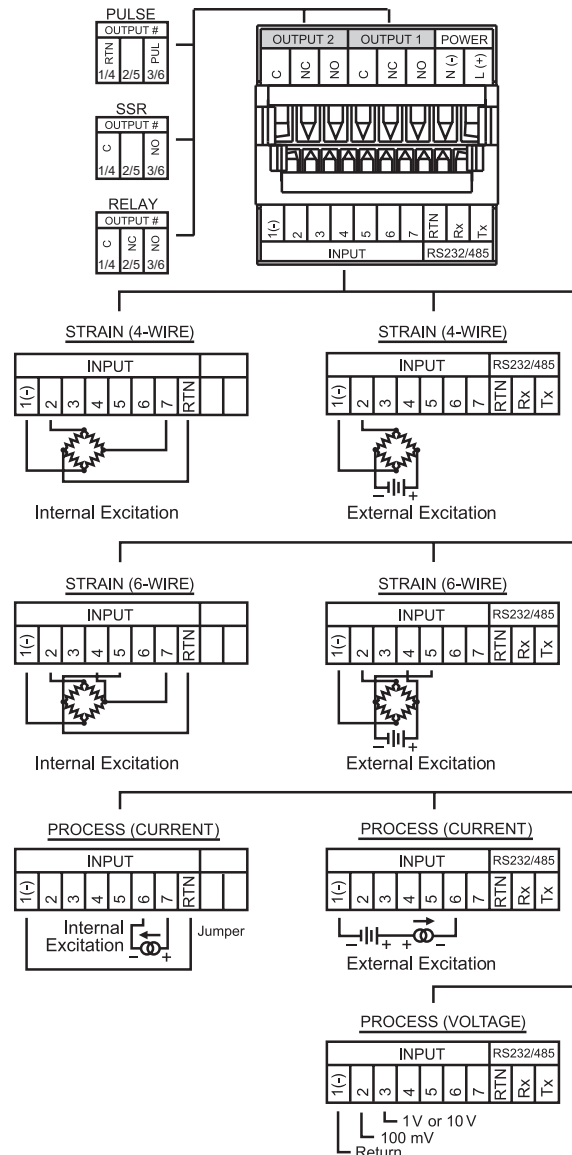

If instrument has the communication option, the internal excitation is not available. Use external excitation to power your transducer.

Connect the main power connections as shown in the figure below.

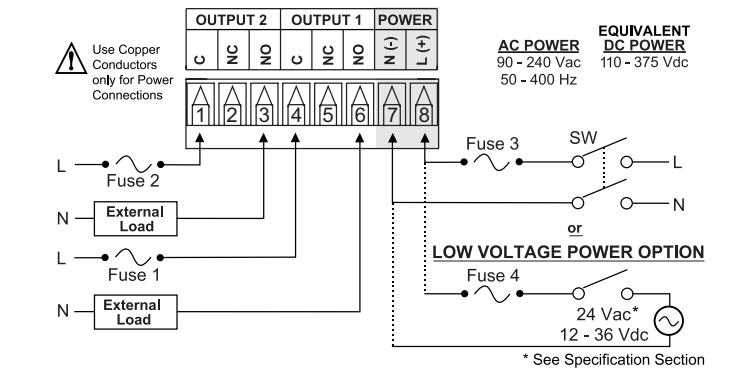

| FUSE | Connector | Output Type | For 115Vac | For 230Vac | DC |
|--------|-----------|-------------|------------|------------|-----------|
| FUSE 1 | Output 1 | Relay | 3 A(T) | 3 A(T) | - |
| FUSE 2 | Output 2 | Relay | 3 A(T) | 3 A(T) | - |
| FUSE 3 | Power | N/A | 100 mA(T) | 100 mA(T) | 100 mA(T) |
| FUSE 4 | Power | N/A | N/A | N/A | 400 mA(T) |



Output 1 and 2 are for -AL Limit Alarm Option only.

CONFIGURATION

Button Functions in Configuration Mode

| | |
|--|---|
| | <ul style="list-style-type: none"> To enter the Menu, the user must first press . Use this button to advance/navigate to the next menu item. The user can navigate through all the top level menus by pressing . While a parameter is being modified, press to escape without saving the parameter. |
| | <ul style="list-style-type: none"> Press the up button to scroll through "flashing" selections. When a numerical value is displayed press this key to increase value of a parameter that is currently being modified. Holding the button down for approximately 3 seconds will speed up the rate at which the setpoint value is incremented. In the Run Mode pressing causes the display to flash the PEAK or GROSS value – press again to return to the Run Mode. |
| | <ul style="list-style-type: none"> Press the down button to go back to a previous Top Level Menu item. Press this button twice to reset the controller to the Run Mode. When a numerical value is flashing (except setpoint value) press to scroll digits from left to right allowing the user to select the desired digit to modify. When a setpoint value is displayed press to decrease value of a setpoint that is currently being modified. Holding the button down for approximately 3 seconds will speed up the rate at which the setpoint value is decremented. In the Run Mode pressing causes the display to flash TARE value to tare your reading (zeroing). |
| | <ul style="list-style-type: none"> Press the enter button to access the submenus from a Top Level Menu item. Press to store a submenu selection or after entering a value — the display will flash a SEt message to confirm your selection. To reset flashing PEAK or GROSS press . In the Run Mode, press twice to enable Standby Mode with flashing StBy. |



Reset: Except for Alarms, modifying any settings of the menu configuration will reset the controller prior to resuming Run Mode.

DISPLAY ABBREVIATIONS

| | | | |
|---------|--|---------|---|
| SP1 | Set Point 1 Value | SP2 | Set Point 2 Value |
| CNFG | Configuration Menu | INPt | Input Type (range) |
| 0 - 1.0 | 1 V Input Voltage | 0 - 0.1 | 100 mV Input Voltage |
| 0 - 20 | 20 mA Input Current | 0 - 10 | 10 V Input Voltage |
| Rtio | Ratiometric Operation | RESO | Display Resolution |
| bUtN | Button Peak/Gross | PEAK | Peak Value |
| GROS | Gross Value | | |
| RdG | Reading Configuration | | |
| dEC | Decimal Point | F.FFF | Decimal Point Position |
| | | ..FFFF | Decimal Point Position |
| LOAD | Input Load | EnbL | Scaling with Known Loads (Actual Value) |
| DSbL | Scaling without Known Loads (Calculated Value) | L.Pnt | Linearization Points |
| 0002.. | Number of Linearization Points | FLtR | Filter Constant |
| ..0010 | Filter Constant Value | IN.Rd | Input/Reading Scale and Offset Menu |
| 0011.. | Filter Constant Value | | |
| ..0128 | Filter Constant Value | | |
| IN 1 | Input 1 | Rd 1 | Reading 1 |
| IN 2 | Input 2 | Rd 2 | Reading 2 |
| | | | |
| IN 10 | Input 10 | Rd 10 | Reading 10 |
| ALR1 | Alarm 1 Menu | AbSo | Absolute Mode |
| dEV | Deviation Mode | LtcH | Latched Mode |
| UNLt | Unlatched Mode | Ct.CL | Contact Closure |
| N.o. | Normally Open | N.c. | Normally Closed |
| ActV | Active Type | AboV | Active Above |
| bELo | Active Below | Hi.Lo | Above High/Below Low |
| bAnd | Above or Below Band | A.P.oN | Alarm Enable/Disable at Power On |
| ALR.L | Alarm Low Value | ALR.H | Alarm High Value |
| ALR.2 | Alarm 2 Menu | | |
| SP.dN | Set Point Deviation | | |
| Id | ID Code Menu | CH.Id | Change ID Code |
| FULL | Full ID | SP.Id | Set Point ID |
| COMM | Communication Option* | NONE | Communication is Not Installed |
| C.PAR | Communication Parameters | baUD | Baud Rate |
| PRtY | Parity | odd | Odd |
| EVEN | Even | No | No |
| dAtA | Data Bit | 7.bit | 7 Data Bit |
| 8.bit | 8 Data Bit | StOP | Stop Bit |
| 1.bit | 1 Data Bit | 2.bit | 2 Stop Bit |
| bus.F | Bus Format | M.bus | Modbus Protocol |
| LF | Line Feed | ECHO | Echo |
| StNd | Communication Standard | 232C | RS-232 |
| 485 | RS-485 | ModE | Data Flow Mode |
| CMD | Command Mode | CoNt | Continuous Mode |
| SEPR | Data Separation Character | SPCE | Space |
| cR | Carriage Return | dAt.F | Data Format |
| stAt | Alarm Status | RdNG | Transmit Reading Value |
| PEAK | Transmit Peak Value | GROS | Transmit Gross Value |
| UNit | Units of Measurement | AddR | Multipoint Address |
| tR.tM | Transmit Color Selection | | |
| COLR | Display Color Selection | N.CLR | Normal Color Display |
| 1.CLR | Alarm 1 Color Display | 2.CLR | Alarm 2 Color Display |
| REd | Display Color is Red | AMbR | Display Color is Amber |
| GRN | Display Color is Green | | |
| dSbL | Disable | ENbL | Enable |
| ERRO | Error | + OL | Input (+) Overload |

* For abbreviations of Communication Option see Communication Manual.