

DISPLAY ABBREVIATIONS

ALR1	Alarm 1 Status		
OFF	Alarm 1 set Off	ON	Alarm 1 set On
A1Md	Alarm 1 Mode		
A1LO	Alarm 1 Low	A1HI	Alarm 1 High
A1LH	Alarm 1 Low/High		
LO-1	Alarm 1 Low	-999.. ..9999	Alarm 1 Low Value
HI-1	Alarm 1 High	-999.. ..9999	Alarm 1 High Value
A1CR	Display color when Alarm 1 triggered		
GRN	Green Color	REd	Red Color
AMbR	Amber Color		
ALR2	Alarm 2 Status		
OFF	Alarm 2 set Off	ON	Alarm 2 set On
A2Md	Alarm 2 Mode		
A2LO	Alarm 2 Low	A2HI	Alarm 2 High
A2LH	Alarm 2 Low/High		
LO-2	Alarm 2 Low	-999.. ..9999	Alarm 2 Low Value
HI-2	Alarm 2 High	-999.. ..9999	Alarm 2 High Value
A2CR	Display color when Alarm 2 triggered		
GRN	Green Color	REd	Red Color
AMbR	Amber Color		
Out	Alarm Latched/Unlatched selection		
LAtC	Latched	UNLA	Unlatched
NO.CR	Display Color in Normal condition		
GRN	Green Color	REd	Red Color
AMbR	Amber Color		
MOdE	Data Flow Mode		
HOSt	Host Mode	SLAV	Slave Mode
baUd	Baud Rate	300.. ..19200	Baud Rate Value
FORM	Data Format		
7O1	7 Bit, Odd, 1 Stop Bit	7E1	7 Bit, Even, 1 Stop Bit
8N1	8 Bit, No parity, 1 Stop Bit		
COMM	Communication Standard		
232	RS-232 Standard	485	RS-485 Standard
AddR	Device Address	0000.. ..0099	Address Value
Miscellaneous:			
PEak	Peak Value	VALL	Valley Value
PROC	Process Value	RUN	Run Mode
OVLd	Input Overload	StOR	Stored Message

OPERATIONS

In **Slave Mode** the Remote Display will wait for commands and data from the Serial Bus.

In **Host Mode** the Remote Display will send data automatically and continuously into the Serial Bus.

When used in **RS-485 Mode**, the device must be accessed with an appropriate **Address Value**.

Latched Mode: Alarm remains latched until reset. To reset already latched alarm select any menu items and then press "up" or "down" button.

- Note** 1. In the examples for RS-485 it is assumed that the device address is 01.
2. Decimal Point over 2 digits (ex:0.001) not recommended for RD4.

Write alphanumeric characters to the Remote Display from the computer (Display in Slave Mode)

- Single Remote Display: (RS232) write 4(6) characters, then CR (carriage return)
- Multiple Remote Display: (RS485) write *, device address (2 digit), CR, 4(6) characters, then CR
- How to display time format or colon ":", ex: 12:30, from keyboard enter: 1230!

Host mode uses Newport product protocols

Process Value (Display on Host Mode)

Press **▲** to request "Process" Value.
a) RS-232 Mode, will send: *X01
b) RS-485 Mode, will send: *01X01

Note If the RD4/RD6 is used with an iDRN/iDRX product, the meter will display Valley or Peak value depending on the jumper position on J14.

J14-1 Closed: factory default position
J14-1 Open: applies only for iDRN/iDRX-PR/-ST/-FP models
J14-2 and J14-3: Do not remove, for factory use only.

Peak Value (Display on Host Mode)

Press **▲** to request "Peak" value:
a) RS-232 Mode, will send: *X02 (or *X03 **†**)
b) RS-485 Mode, will send: *01X02 (or *01X03 **†**)

Valley Value (Display on Host Mode)

Press **▼** to request "Valley" value.
a) RS-232 Mode, will send: *X03 (or *X04 **†**)
b) RS-485 Mode, will send: *01X03 (or *01X04 **†**)
† = if connected with iDRN/iDRX-PR/-ST/-FP models

Display Color Setup (Alarm Setup)

This menu allows the user to select the color of the display in normal conditions and when alarm is triggered. If user wants the Display to change color every time when both Alarm 1 and Alarm 2 are triggered, the Alarm values should be set in such a way that Alarm 1 is always on the top of Alarm 2 value, otherwise value of the Alarm 1 will overwrite value of Alarm 2 and Display color would not change when Alarm 2 is triggered.

Example 1:

Alarm 1 setup: "ON", Alarm Mode High "A1HI", Alarm High Value "HI-1"=400, Alarm Color "A1CR"=Amber

Alarm 2 setup: "ON", Alarm Mode High "A2HI", Alarm High Value "HI-2"=200, Alarm Color "A2CR"=Red

Normal Color: "NO.CR"=Green

Display colors change sequences:

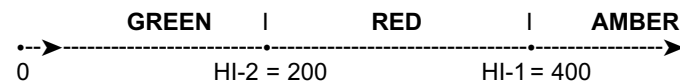

Example 2:

Alarm 1 setup: "ON", Alarm Mode Low "A1LO", Alarm Low Value "LO-1"=100, Alarm Color "A1CR"=Amber

Alarm 2 setup: "ON", Alarm Mode LO "A2LO", Alarm High Value "LO-2"=300, Alarm Color "A2CR"=Red

Normal Color: "NO.CR"=Green

Display colors change sequences:

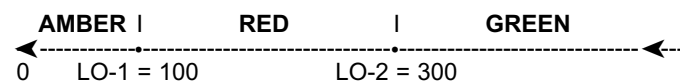

Example 3:

Alarm 1 setup: "ON", Alarm Mode Low/High "A1LH", Alarm Low Value "LO-1"=100, Alarm High Value "HI-1"=250, Alarm Color "A1CR"=Amber

Alarm 2 setup: "ON", Alarm Mode Low/High "A2LH", Alarm Low Value "LO-2"=150, Alarm High Value "HI-2"=200, Alarm Color "A2CR"=Red

Normal Color: "NO.CR"=Green

Display colors change sequences:

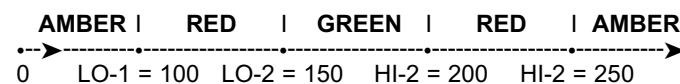

Display Color Change (by serial communication)

Using Microprocessor Version 1.6 and above, while in Slave mode, with alarms disabled. ~~~R to turn the display Red.

~~~G to turn the display Green.

~~~O to turn the display Amber.

SPECIFICATION

Display:

RD4: 4-digit, 9-segment LED,
21 mm (0.83")

RD6: 6-digit, 9-segment LED,
17 mm (0.67")

with red, green and amber programmable colors.

Alarm: Alarm 1 & 2 programmable Latch/Unlatch, High, Low, High/Low

Serial Input: Serial ASCII RS-232 or RS-485 Menu selectable

Input levels: RS-232 and RS-485 Standard Voltage levels.

Baud Rate: 300, 600, 1200, 2400, 4800, 9600, 19200

RS-485 address: 0 to 99

Data Format: 7O1-7 bit, Odd, 1 stop bit

7E1- 7 bit, even, 1 stop bit

8N1 - 8 bit, No parity, 1 stop bit.

Power Supply: 10 to 36 VDC (2 W) or AC adapter 120/240 VAC to 12 VDC (200 mA).

Operating Temperature: 0 to 50°C

Storage Temperature: -20 to 85°C

Relative Humidity: 0 to 85 %

Protection:

NEMA-4x (IP65) front Bezel only.

Dimensions: 48 H x 96 W x 38 D mm (1.89" x 3.78" x 1.5")

Panel Cutout:

1.772" (45 mm) x 3.622" (92 mm)

Approvals: CE per EN61010-1:2001

WARNING: These products are not designed for use in, and should not be used for, patient-connected applications.

This device is marked with the international caution symbol. It is important to read the Setup Guide before installing or commissioning this device, as the guide contains important information relating to safety and EMC.

It is the policy of NEWPORT to comply with all worldwide safety and EMC/EMI regulations that apply. NEWPORT is constantly pursuing certification of its products to the European New Approach Directives. NEWPORT will add the CE mark to every appropriate device upon certification.

The information contained in this document is believed to be correct, but NEWPORT Electronics, Inc. accepts no liability for any errors it contains, and reserves the right to alter specifications without notice.

TRADEMARK NOTICE:

NEWPORT, **NEWPORT**, newportUS.com[®] and the "Meter Bezel Design" are Trademarks of NEWPORT ELECTRONICS, INC.

WARRANTY/DISCLAIMER

NEWPORT Electronics, Inc. warrants this unit to be free of defects in materials and workmanship for a period of **one (1) year** from the date of purchase. In addition to NEWPORT's standard warranty period, NEWPORT Electronics will extend the warranty period for **four (4) additional years** if the warranty card enclosed with each instrument is returned to NEWPORT.

If the unit malfunctions, it must be returned to the factory for evaluation. NEWPORT's Customer Service Department will issue an Authorized Return (AR) number immediately upon phone or written request. Upon examination by NEWPORT, if the unit is found to be defective, it will be repaired or replaced at no charge. NEWPORT's WARRANTY does not apply to defects resulting from any action of the purchaser, including but not limited to mishandling, improper interfacing, operation outside of design limits, improper repair, or unauthorized modification. This WARRANTY is VOID if the unit shows evidence of having been tampered with or shows evidence of having been damaged as a result of excessive corrosion, or current, heat, moisture or vibration; improper specification; misapplication; misuse or other operating conditions outside of NEWPORT's control. Components which wear are not warranted, including but not limited to contact points, fuses, and tracs.

NEWPORT is pleased to offer suggestions on the use of its various products. However, NEWPORT neither assumes responsibility for any omissions or errors nor assumes liability for any damages that result from the use of its products in accordance with information provided by NEWPORT, either verbal or written. NEWPORT warrants only that the parts manufactured by it will be as specified and free of defects.

NEWPORT MAKES NO OTHER WARRANTIES OR REPRESENTATIONS OF ANY KIND WHATSOEVER, EXPRESS OR IMPLIED, EXCEPT THAT OF TITLE, AND ALL IMPLIED WARRANTIES INCLUDING ANY WARRANTY OF MERCHANTABILITY AND FITNESS FOR A PARTICULAR PURPOSE ARE HEREBY DISCLAIMED.

LIMITATION OF LIABILITY: The remedies of purchaser set forth herein are exclusive, and the total liability of NEWPORT with respect to this order, whether based on contract, warranty, negligence, indemnification, strict liability or otherwise, shall not exceed the purchase price of the component upon which liability is based. In no event shall NEWPORT be liable for consequential, incidental or special damages.

CONDITIONS: Equipment sold by NEWPORT is not intended to be used, nor shall it be used: (1) as a "Basic Component" under 10 CFR 21 (NRC), used in any nuclear installation or activity; or (2) in medical applications or used on humans. Should any Product(s) be used in or with any nuclear installation or activity, medical application, or used on humans, or misused in any way, NEWPORT assumes no responsibility as set forth in our basic WARRANTY/DISCLAIMER language, and, additionally purchaser will indemnify NEWPORT and hold NEWPORT harmless from any liability or damage whatsoever arising out of the use of the Product(s) in such a manner.

RETURN REQUEST/INQUIRIES

Direct all warranty and repair requests/inquiries to the NEWPORT Customer Service Department. BEFORE RETURNING ANY PRODUCT(S) TO NEWPORT, PURCHASER MUST OBTAIN AN AUTHORIZED RETURN (AR) NUMBER FROM NEWPORT'S CUSTOMER SERVICE DEPARTMENT (IN ORDER TO AVOID PROCESSING DELAYS). The assigned AR number should then be marked on the outside of the return package and on any correspondence.

The purchaser is responsible for shipping charges, freight, insurance and proper packaging to prevent breakage in transit.

FOR WARRANTY RETURNS, please consult NEWPORT for current repair BEFORE contacting NEWPORT:

- Purchase Order number under which the product was PURCHASED,
- Model and serial number of the product under warranty, and
- Repair instructions and/or specific problems relative to the product.

FOR NON-WARRANTY REPAIRS, have the following information available BEFORE contacting NEWPORT:

- Purchase Order number to cover the COST the repair,
- Model and serial number of product, and
- Repair instructions and/or specific problems relative to the product.

NEWPORT's policy is to make running changes, not model changes, whenever an improvement is possible. This affords our customers the latest in technology and engineering.

NEWPORT is a registered trademark of NEWPORT Electronics, Inc.

© Copyright 2005 NEWPORT Electronics, Inc. All rights reserved.

This document may not be copied, photocopied, reproduced, translated, or reduced to any electronic medium or machine-readable form, in whole or in part, without the prior written consent of NEWPORT Electronics, Inc.

PATENT NOTICE: This product is covered by one or more of the following patents: U.S. Pat. No. Des. 336,895; 5,274,577; 6,243,021 / Canada 2052599; 2052600 / Italy 1249456; 1250938 / France Brevet No. 91 12756 / Spain 2039150; 2048066 / UK Patent No. GB 249 837; GB 248 954 / Germany DE 41 34398 C2. The **NEWPORT** is a Trademark of OMEGA Engineering, Inc. USED UNDER LICENSE. Other U.S. and International patents pending or applied for.

OPERATION MANUAL



RD4 / RD6 Remote Display

For immediate technical or application assistance please call:

1-800-6397678
1-800-NEWPORT

Newport Electronics, Inc.

2229 South Yale Street • Santa Ana, CA • 92704 • U.S.A.

TEL: (714) 540-4914 • FAX: (203) 968-7311

Toll Free: 1-800-639-7678 • www.newportUS.com • e-mail: info@newportUS.com

ISO 9001 Certified

Newport Technologies, Inc.

976 Bergar • Laval (Quebec) • H7L 5A1 • Canada

TEL: (514) 335-3183 • FAX: (514) 856-6886

Toll Free: 1-800-639-7678 • www.newport.ca • e-mail: info@newport.ca

Newport Electronics, Ltd.

One Omega Drive • River Bend Technology Centre

Northbank, Irlam • Manchester M44 5BD • United Kingdom

Tel: +44 161 777 6611 • FAX: +44 161 777 6622

Toll Free: 0800 488 488 • www.newportuk.co.uk • e-mail: sales@newportuk.co.uk

Newport Electronics B.V.

Postbus 8034 • 1180 LA Amstelveen • The Netherlands

TEL: +31 20 3472121 • FAX: +31 20 6434643

Toll Free: 0800 0993344 • www.newport.nl • e-mail: info@newport.nl

Newport Electronics spol s.r.o.

Frystatska 184, 733 01 Karviná • Czech Republic

TEL: +420 59 6311899 • FAX: +420 59 6311114

Toll Free: 0800-1-66342 • www.newport.cz • e-mail: info@newport.cz

Newport Electronics GmbH

Daimlerstrasse 26 • D-75392 Deckenfronn • Germany

TEL: 49 7056 9398-0 • FAX: 49 7056 9398-29

Toll Free: 0800 / 6397678 • www.newport.de • e-mail: sales@newport.de

Newport Electronique S.A.R.L.

11, rue Jacques Cartier • 78280 Guyancourt • France

TEL: +33 1 61 37 29 00 • FAX: +33 1 30 57 54 27

Toll Free: 0800 466 342 • www.newport.fr • e-mail: sales@newport.fr

Mexico and Latin America

FAX: 001 (203) 359-7807

En Español: 001 (203) 359-7803

NEWPORTnet™ On-Line Service www.newportUS.com
Internet e-mail info@newportUS.com

NEWPORT Electronics, Inc.

DESCRIPTION:

The RD4 and RD6 are 4(6) digit master/slave displays providing remote readout from instruments such as programmable controllers, digital panel meters and other instruments with serial output. Two communication interfaces are supported in Remote Display: RS-232 and RS-485 and can be programmed through front panel buttons.

The RD4/RD6 remote display can be mounted in a 1/8 DIN panel cut-out or surface mounted with the included bale.

The Remote Display features big bright 21mm (0.83") and 17.3mm (0.68") 9 segment LED's that can be programmed to change color between Green, Amber, and Red to indicate alarms.

Serial Communications can be made to an RJ-11 jack or screw terminals. In the Slave mode, the RD4/RD6 can be used for displaying Alphanumeric characters from a computer.

Power is supplied from 10 to 36 Vdc power supply or AC adapter 120/240 Vac to 12 Vdc (200 mA).

Compatible Host device must feature serial RS232 or RS485 output.

SAFETY:

- The instrument is a panel mount device protected in accordance with EN61010-1:2001.
- This device does not provide safety isolation. Therefore, always use a Safety Agency Approved DC power source.

EMC:

- Whenever EMC is an issue, always use shielded cables.
- Never run signal and power wires in the same conduit.
- Use signal wire connections with twisted-pair cables.
- Install Ferrite Bead(s) on signal wire close to the instrument if EMC problems persist.

MOUNTING

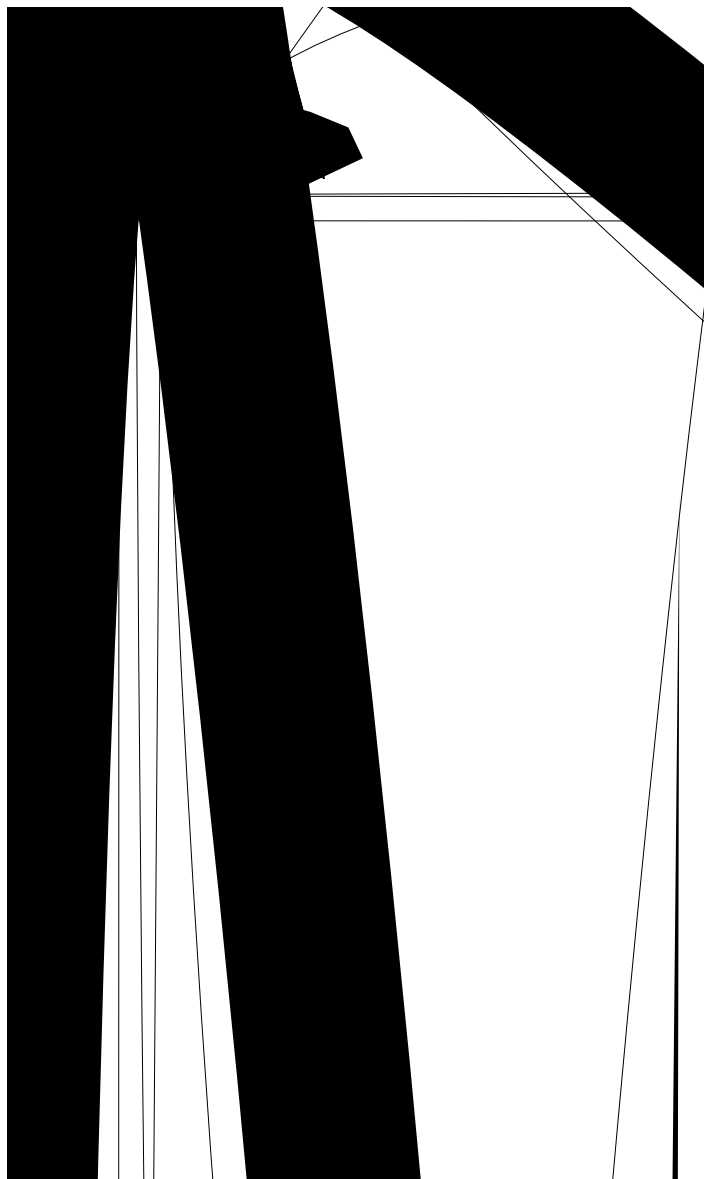

1. Using the panel cutout diagram shown above, cut an opening in the panel.
2. Remove two screws at the back of remote display to remove back cover.
3. Insert the unit into the opening from the front of the panel, so the gasket seals between the bezel and the front of the panel.
4. Align back cover to remote display and reinstall screws.

Mounting Remote Display on Bail:

1. Use the Remote Display template to mark the location of mounting screws on the flat surface.
2. Be sure to leave enough room around the bail (as noted on the template drawing) to allow for removal and rotation of the display.
3. The display can be rotated to 12 positions for the best viewing angle.

Disassembly Instruction:

Warning: Disconnect all ac power from the unit before proceeding.

1. Remove all wiring connections from the rear of the instrument, by unplugging the power and input connectors.
2. Remove two screws at the back of remote display and back cover.
3. Remove the Remote Display from the panel.
4. To remove the Remote Display from the bail, spread mounting ears.

WIRING

Wiring RS-232 Interface.

The RS-232 standard (point-to-point) allows a single device to be connected to the Remote Display using a three-wire connection (full duplex).

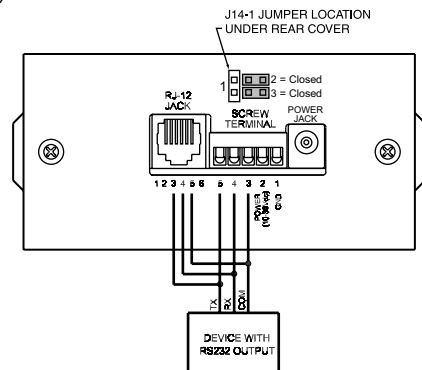

| Device with RS-232
Pin Function | Host Mode | | Slave Mode |
|------------------------------------|-----------|-----------------|-----------------|
| | RJ-12 | Screw Terminals | Screw Terminals |
| Receive (Rx) | 4 | 5 | 4 |
| Transmit (Tx) | 3 | 4 | 5 |
| Ground (RTN) | 5 | 3 | 3 |

Wiring RS-485 Interface.

The RS-485 standard (multipoint) allows a computer, one or more devices and Remote Displays (up to 32) to be connected using a two-wire connection (half-duplex) plus a common wire to connect to the shield of the cable. It is recommended to use shielded cable with one twisted pair for EMI noise protection.

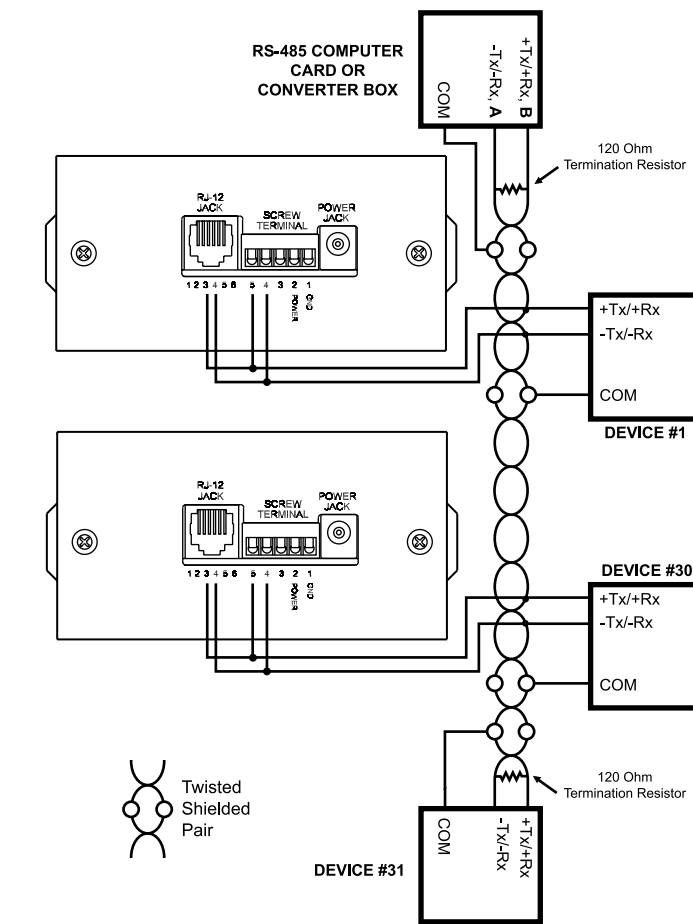

Note: Connections to the computer are optional.

| Computer Card or Converter Box
Pin Function | Device with RS-485 Pin
Function | Remote Display | |
|--|------------------------------------|----------------|----------------|
| | | RJ-12 | Screw Terminal |
| A, -Tx/-Rx | -Tx/-Rx | 4 | 4 |
| B, +Tx/+Rx | +Tx/+Rx | 3 | 5 |
| COM | COM | | 3 |

Power Connection.

Connect the main power connections as shown in the figure below.

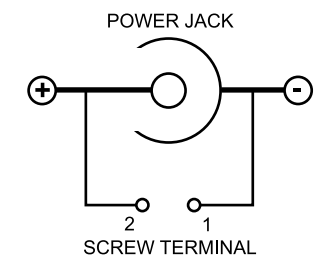

CONFIGURATION

Button Functions in Configuration Mode

| | |
|----------------|--|
| (MENU) | <ul style="list-style-type: none"> • To enter the Menu, the user must first press (MENU) button. • Use this button to advance/navigate to the next menu item. The user can navigate through all the top level menus by pressing (MENU). • While a parameter is being modified, press (MENU) to escape without saving the parameter. |
| (UP) | <ul style="list-style-type: none"> • Press the up (UP) button to scroll through submenu selections. When a numerical value is displayed press this key to increase value of a parameter that is currently being modified. • In the Run Mode pressing (UP) causes the display to flash the PEAK value several times before returning to the Run Mode. • In the top menu press (UP) causes the display to return to the Run Mode. |
| (DOWN) | <ul style="list-style-type: none"> • Press the down (DOWN) button to scroll through submenu selections. When a numerical value is displayed press this key to decrease value of a parameter that is currently being modified. • In the Run Mode press (DOWN) causes the display to flash the Valley value several times before returning to the Run Mode. • In the top menu press (DOWN) causes the display to return to the Run Mode. |
| (ENTER) | <ul style="list-style-type: none"> • Press this button to access the submenus from a Top Level Menu item. • Press this button to store a submenu selection or after entering a value – the display will flash a StOR message to confirm your selection. |

FLOW CHART

Below is a flowchart showing how to navigate through all menus by pressing front buttons.

