



iServer™

Industrial MicroServer™ EIS-2 and EIS-2-RJ

Operator's Manual



N® **NEWPORT** Electronics, Inc.
<http://www.newportUS.com/iServer>

Additional products from

NEWPORT Electronics, Inc.

Counters	Rate Meters
Frequency Meters	Timers
PID Controllers	Totalizers
Clock/Timers	Strain Gauge Meters
Printers	Voltmeters
Process Meters	Multimeters
On/Off Controllers	Soldering Iron Testers
Recorders	pH pens
Relative Humidity	pH Controllers
Transmitters	pH Electrodes
Thermocouples	RTDs
Thermistors	Thermowells
Wire	Flow Sensors

For Immediate Assistance
In the U.S.A. and Canada: 1-800-NEWPORT[®]
In Mexico: (95) 800-NEWPORTSM
Or call your local NEWPORT Office.

NEWPORTnetSM On-Line Service
www.newportUS.com

Internet e-mail
info@newportUS.com

It is the policy of NEWPORT to comply with all worldwide safety and EMC/EMI regulations that apply. NEWPORT is constantly pursuing certification of its products to the European New Approach Directives. NEWPORT will add the CE mark to every appropriate device upon certification.

The information contained in this document is believed to be correct but NEWPORT Electronics, Inc. accepts no liability for any errors it contains, and reserves the right to alter specifications without notice.

WARNING: These products are not designed for use in, and should not be used for, patient connected applications.

TRADEMARK NOTICE: ,  **NEWPORT**, **NEWPORT[®]** and **newportUS.com** are trademarks of NEWPORT Electronics, Inc.

PATENT NOTICE: This product is covered by one or more of the following patents: U.S. Pat. No. Des. 336,895; 5,274,577/ CANADA 2052599; 2052600/ ITALY 1249456; 1250938 / FRANCE BREVET No. 91 12756 / SPAIN 2039150; 2048066 / UK PATENT No. GB2 249 837; GB2 248 954 / GERMANY DE 41 34398 C2. The  is a Trademark of OMEGA Engineering, Inc. Used Under License. Other US and International Patents pending or applied for.



This device is marked with the international caution symbol. It is important to read the Setup Guide before installing or commissioning this device as it contains important information relating to safety and EMC.

TABLE OF CONTENTS

Part 1: Introduction		
1.1	Safety and EMC Considerations	2
1.2	Before You Begin	2
1.3	Description	3
Part 2: Hardware		
2.1a	Mounting on a DIN Rail	4
2.1b	Removal from a DIN Rail	4
2.2	DIP Switches	4
2.3	Parts of iServer Unit	5
2.4	Serial Communication Interfaces	6
2.4.1	Wiring RS232 Interface	7
2.4.2	Wiring RS485 Interface	8
2.5	Network Communication Interfaces	8
2.5.1	10Base-T RJ-45 Pinout	8
2.5.2	10Base-T Crossover Wiring	8
Part 3: Network Configuration		
3.1	Network Protocols	9
3.2	Ethernet (MAC) Address	9
3.3	DHCP	10
3.4	DNS	10
3.5	IP Address	11
3.5.1	Default IP Address	11
3.6	Port Number	11
Part 4: Operations		
4.1	Setup and Operation using the iServer Web Page	13
4.1.1	Read Devices	14
4.1.2	Send Raw Command	14
4.1.3	Modify Device List Entry	15
4.1.4	Configuration	16
4.1.5	Configure Access Control	17
4.1.6	Login	18
4.1.7	Change ID	18
4.2	Setting a New IP Address using the Serial Port	19
4.3	Setting a New IP Address over the Network	21
4.4	Terminal Server Function	22
4.5	Telnet Setup	23
4.6	HTTPGET Program	25
4.7	ARP Protocol	26
4.8	Remote Access (Tunneling)	27
4.8.1	Local iServer	28
4.8.2	Remote iServer	29
4.9	Mail Notifier Software	30
4.9.1	Installation	30
4.9.2	Program Options Setup and Configuration	31
4.9.3	Device Setting Setup and Configuration	33
Part 5: Specifications		33
Part 6: Factory Preset Values		34
Appendix A	Glossary	35
Appendix B	IP Address	36
Appendix C	IP Netmask	37
Appendix D	ASCII Chart	38
	ASCII Chart Control Codes	39
Part 7: Approvals Information		
7.1	Electromagnetic Compatibility (EMC)	40
7.2	FCC	40

LIST OF FIGURES:

Figure 1.1	iServer on the Ethernet Network	3
Figure 2.1a	Mounting	4
Figure 2.1b	Removal	4
Figure 2.2	DIP Switches	4
Figure 2.3	Parts of iServer Unit	5
Figure 2.5	Multi-point, Half-Duplex RS485 Wiring	7
Figure 2.6	RJ45 Pinout	8
Figure 2.7	10Base-T Crossover Cable Wiring	8
Figure 3.1	Labeling	9
Figure 3.2	DIP Switch on Bottom Side of Case	10
Figure 4.1	Pinging eis03ec MS-DOS Prompt	12
Figure 4.2	Device Type Menu	13
Figure 4.3	iServer Home Page Menu	13
Figure 4.4	Read Devices Menu	14
Figure 4.5	Login Password	14
Figure 4.6	Serial Device Query Menu	14
Figure 4.7	Device Setup Menu	15
Figure 4.8	Modify Device List Menu	15
Figure 4.9	Configuration Menu	16
Figure 4.10	Access Control Menu	17
Figure 4.11	Login Menu	18
Figure 4.12	Change ID Menu	18
Figure 4.13	Setting the IP address via the Serial Port	19
Figure 4.14	DIP Switch #1 shown in "ON" Position	19
Figure 4.15	Pinging 128.100.101.70 from the MS-DOS Prompt	20
Figure 4.16	Access Control Menu	21
Figure 4.17	Terminal Server Configuration	22
Figure 4.18	Tera Term Telnet Connection Screen	23
Figure 4.19	Telnet Setup Menu - iServer Configuration Page	23
Figure 4.20	Telnet Setup Menu - iServer Help Page	24
Figure 4.21	ARP Commands and Responses	26
Figure 4.22	PC-to-Device Communication	27
Figure 4.23	Device-to-Device Communication	27
Figure 4.24	Configuration Menu - Remote iServer	28
Figure 4.25	Configuration Menu - Local iServer	29
Figure 4.26	iServer Mail Notifier Main Window	30
Figure 4.27	iServer Mail Notifier Profile Setup	31
Figure 4.28	iServer Mail Notifier Device Setting	32

LIST OF TABLES:

Table 2.1	Parts of iServer Unit	5
Table 2.2	Communication Interfaces - RS232 and RS485	6
Table 2.3	Connectors	6
Table 2.4	RS485 Half-Duplex Hookup	7

NOTES, WARNINGS and CAUTIONS

Information that is especially important to note is identified by following labels:

- **NOTE**
- **WARNING or CAUTION**
- **IMPORTANT**
- **TIP**



Note E-S

NOTE: Provides you with information that is important to successfully setup and use the iServer.



CAUTION or WARNING: Tells you about the risk of electrical shock.



CAUTION, WARNING or IMPORTANT: Tells you of circumstances or practices that can effect the instrument's functionality and must refer to accompanying documents.



Tip E-S

TIP: Provides you helpful hints.

PART 1 INTRODUCTION

1.1 Safety and EMC Considerations

The instrument is a Class III device (10 to 32 Vdc).
Always use a power supply, which complies with EN 60950 safety standard.

EMC Considerations

- Whenever EMC is an issue, always use shielded cables.
- Never run signal and power wires in the same conduit.
- Use signal wire connections with twisted-pair cables.
- Install Ferrite Bead(s) on signal wires close to the instrument if EMC problems persist.

Failure to follow all instructions and warnings may result in injury!

1.2 Before You Begin

Inspecting Your Shipment:

Remove the packing slip and verify that you have received everything listed. Inspect the container and equipment for signs of damage as soon as you receive the shipment. Note any evidence of rough handling in transit. Immediately report any damage to the shipping agent. The carrier will not honor damage claims unless all shipping material is saved for inspection. After examining and removing the contents, save the packing material and carton in the event reshipment is necessary.

Customer Service:

If you need assistance, please contact the Customer Service Department nearest you.

Manuals, Software:

The latest Operation Manual as well as free iSeries configuration software and iServer Mail Notifier are available at **the website listed on the cover page of this manual or on the CD-ROM enclosed with your shipment.**

1.3 Description

Note This device can be purchased as a stand alone DIN Rail mounted unit, or as a bench/wall mount unit.

The iServer is a stand alone Ethernet Server designed to connect devices with serial interfaces to the Ethernet network using the TCP/IP protocol. It contains Ethernet and RS-232/485/422 interfaces.

The standard features include:

- Use standard Web Browser , TCP connection, HTTPGET DOS program or Telnet Simulation, for network connectivity.
- Install via RS-232/485/422 serial port connection.
- Transfer data from RS-232/485/422 serial interface to TCP/IP using built-in socket server.
- Use a standard home page or customize Web page for OEM applications.

The following example illustrates how you can hook up the devices with serial interface on the network using the iServer:

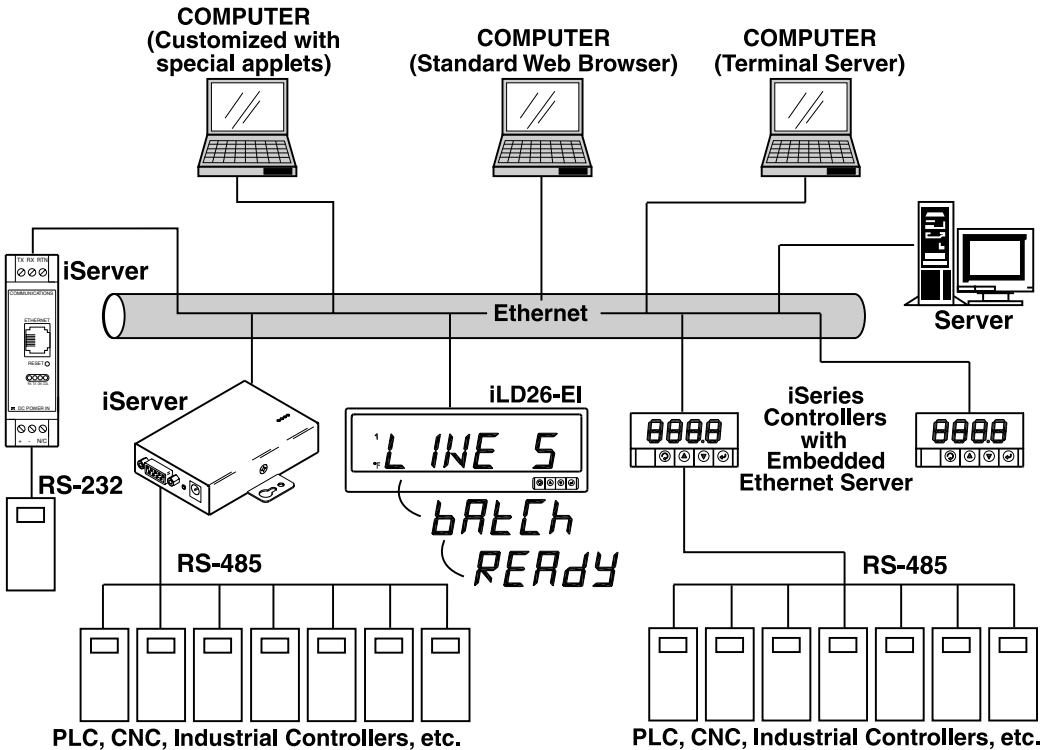

Figure 1.1 iServer on the Ethernet Network

PART 2 HARDWARE

2.1a Mounting on a DIN Rail

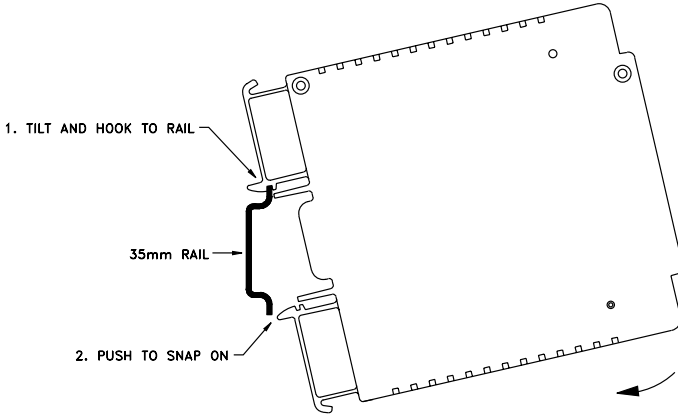

Figure 2.1 Mounting

To install unit onto DIN Rail:

- Tilt unit, position mounting slot onto DIN Rail, as shown.
- Push unit towards DIN Rail and it will snap into place.

2.1b Removal from a DIN Rail

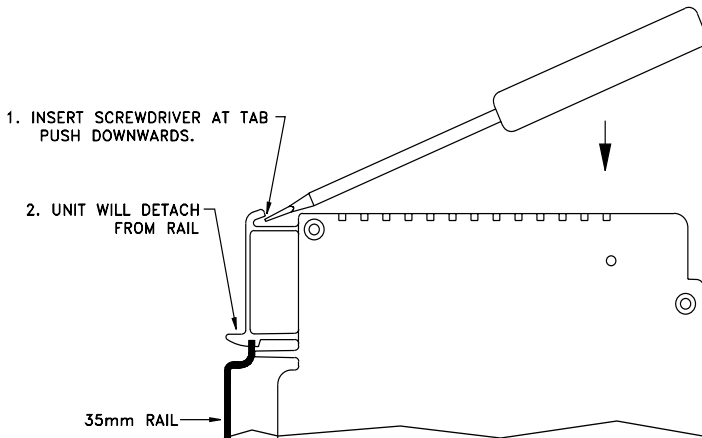

Figure 2.2 Removal

- Insert flat screw-driver into tab and push downwards.
- Unit will detach from DIN Rail.

2.2 DIP Switches

Note

The iServer is shipped with all DIP switches in "OFF" position

- To change the IP address from the serial port
- To change to default factory settings
- To enable/disable DHCP
- To enable/disable Terminal Server function

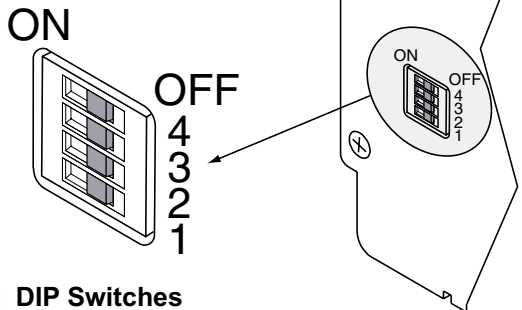
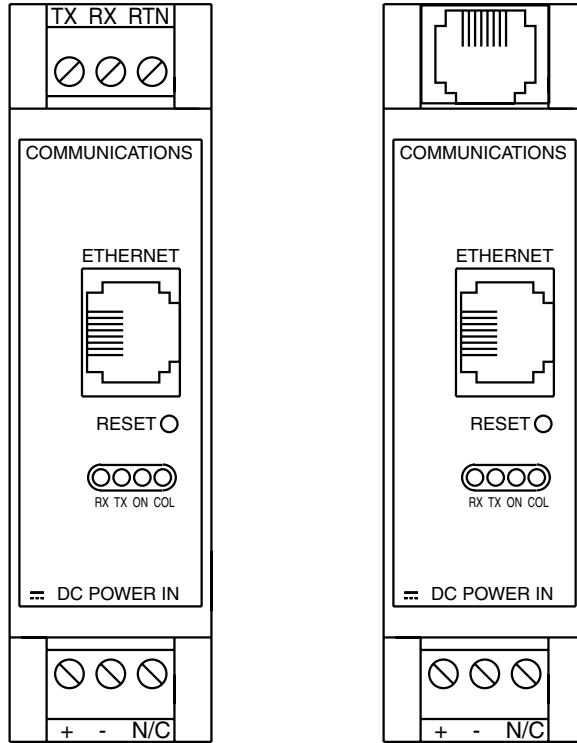

Figure 2.2 DIP Switches

2.3 Parts of the iServer Unit



EIS-2

EIS-2-RJ

Figure 2.3 Parts of the iServer Unit

Table 2.1 Parts of iServer Unit

SERIAL	Screw Terminal Block or RJ45 for RS-232 / RS-485 / RS-422 connections.
ETHERNET	RJ45 interface for 10BASE-T connection.
RESET	Button: Used for power resetting the iServer.
COL	LED (Red) Blinking: Indicates network activities (receiving or sending packets).
ON	LED (Green) Solid: Indicates good network link.
TX	LED (Yellow) Blinking: Indicates transmitting data to the serial port.
RX	LED (Green) Blinking: Indicates receiving data on the serial port.
DC Power Supply Section:	
+	Plus Power Supply Wire connection.
-	Minus Power Supply Wire connection.

2.4 Serial Communication Interfaces

Two communication interfaces are supported in the iServer: RS232 and RS-485. These standards define the electrical characteristics of a communication network. The RS485 port of the iServer is fully compatible to use with RS-485 and RS-422 instruments. The RS485 is an extended version of the RS422 communication standard which increases the allowable number of devices from 10 to 32 by improving the electrical characteristics.

- The **RS232** standard (point-to-point) allows a single device to be connected to an iServer. The EIS-2-RJ operates with full-duplex RS232 using eight wires: Rx-receive, Tx-transmit, DTR, DSR, DCD, CTS, RTS and common ground wires. The EIS-2 operates with 3-wire RS-232 port: Tx, Rx, and GND. RS232 cable length is limited to 50 feet.
- The **RS485** standard (multi-point) allows one or more devices (multi-dropped) to be connected to the iServer using a two-wire connection (half-duplex) +Rx/+Tx and -Rx/-Tx. Use of RS485 communications allows up to 31 devices to connect to the iServer with cable length up to 4000 feet long.

Note 

Although the RS485 is commonly referred to as a "two wire" connection, the iServer also provides a ground/return shield connection to use as a common connection for EMI noise protection.

Table 2.2 shows the differences between RS232 and RS485 communication interfaces.

Table 2.2

Data Transmission Characteristics	RS232	RS485
Transmission Mode	Single ended	Differential
Electrical connections	3 wire (EIS-2) 8 wire (EIS-2-RJ)	2 wire 2 wire
Drivers per line	1 driver	32 drivers
Receivers per line	1 receiver	32 receiver
Maximum cable length	50 ft (15 meters)	4000 ft (1200 meters)

Note 

Changing between RS232 and RS485 interfaces, as well as modifying the other parameters is possible through the iServer firmware using its home Web page or Telnet connection (see **Part 4** for details).

2.4.1 Wiring RS232 Interface

Table 2.3 shows the signals and the direction of signals on the Screw Terminal Block (EIS-2 model) and RJ45 (EIS-2-RJ model).

Table 2.3 Connectors

EIS-2 RS-232 pinouts Screw Terminal Block Serial Connector
Tx (Transmit)
Rx (Receive)
RTN (Common GND)

EIS-2-RJ pinouts RJ45 Serial Connector			
Pin #	RS-232	Direction	RS-485
1	N/C	N/C	
*2	DCD	IN	
*3	DTR	OUT	
4	GND	--	
5	Rx	IN	Tx+/Rx+
6	Tx	OUT	Tx-/Rx-
*7	CTS	IN	
*8	RTS	OUT	

* These 4 pins can also be used as digital input/output signals (firmware selection).

2.4.2 Wiring RS485 Interface

RS485 interface uses a two-wire communication system (one for transmitting and one for receiving) plus a common wire to connect to the shield of the cable. It is recommended to use a shielded cable with one twisted pair.

Note ESR Use of twisted pair and shield will significantly improve noise immunity.

Figure 2.5 shows multi-point, half-duplex RS485 interface connections for the iServer.

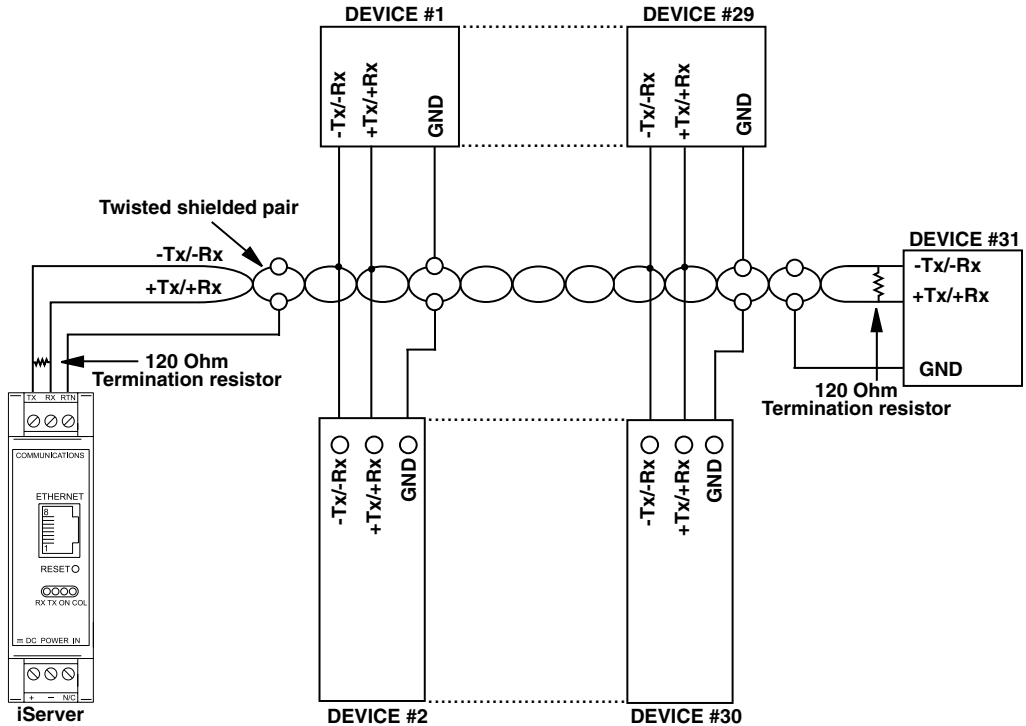

Figure 2.5 Multi-point, Half-Duplex RS485 Wiring

Note ESR Value of the termination resistor is not critical and depends on the cable impedance.

Table 2.4 shows RS485 half-duplex hookup between the iServer serial port and device with RS485 communication interface (EIS-2 model).

Table 2.4

iServer	DEVICE WITH RS485
+Tx/+Rx (+Transmit/+Receive)	+Tx/+Rx (+Transmit/+Receive)
-Tx/-Rx (-Transmit/-Receive)	-Tx/-Rx (-Transmit/-Receive)
RTN (Common GND)	GND (Common GND)

Note ESR See Table 2.3 for the RS-485 pinouts on the EIS-2-RJ model.

2.5 Network Communication Interfaces

2.5.1 10Base-T RJ-45 Pinout

The 10BASE-T Ethernet network (RJ-45) system is used in the iServer for network connectivity. The 10 Mbps twisted-pair Ethernet system operates over two pairs of wires. One pair is used for receiving data signals and the other pair is used for transmitting data signals. This means that four pins of the eight-pin connector are used.

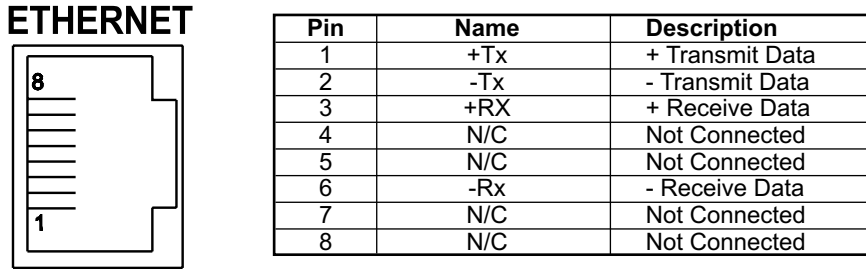

Figure 2.6 RJ45 Pinout

2.5.2 10Base-T Crossover Wiring

When connecting the iServer directly to the computer, the transmit data pins of the computer should be wired to the receive data pins of the iServer, and vice versa. The 10Base-T crossover cable with pin connection assignments are shown on **Figure 2.7**.

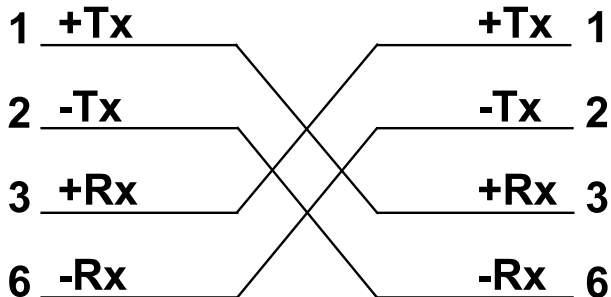

Figure 2.7 10Base-T Crossover Cable Wiring



Use straight through cable for connecting the iServer to an Ethernet hub. The ports on the hub are already crossed.

PART 3 NETWORK CONFIGURATION

3.1 Network Protocols

The iServer can be connected to the network using standard TCP/IP protocols. It also supports ARP, HTTP (WEB server), DHCP, DNS, and Telnet protocols.

3.2 Ethernet (MAC) Address

MAC (Media Access Control) address is your computer's unique hardware number. When you're connected to the LAN from your computer, a correspondence table relates your IP address to your computer's physical (MAC) address. The MAC address can be found on the label of your device and contains 6 bytes (12 characters) of hexadecimal numbers XX:XX:XX:XX:XX:XX hex

For example: 0A:0C:3D:0B:0A:0B



There is room on the label to put your IP address. See **Figure 3.1**.

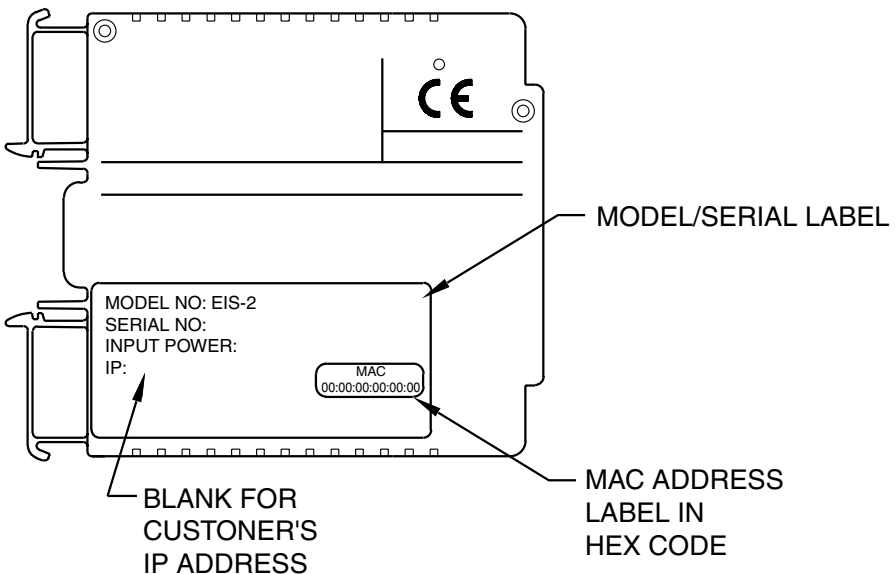

Figure 3.1 Labeling

3.3 DHCP

DHCP, Dynamic Host Configuration Protocol enables individual computers or devices to extract their IP configurations from a server (DHCP server). If the DHCP is enabled on your iServer, as soon as the iServer is connected to the network, there is an exchange of information between DHCP server and the iServer. During this process the IP address, the Gateway address, and the Subnet Mask will be assigned to the iServer by the DHCP server. Note that the DHCP server must be configured correctly to do such assignment.

If fixed or static IP address is desired, the DHCP must be disabled. The iServer is shipped with DHCP disabled (factory default). The DHCP can be enabled by setting the DIP switch # 3 to the “ON” position (refer to **Figure 3.2**).

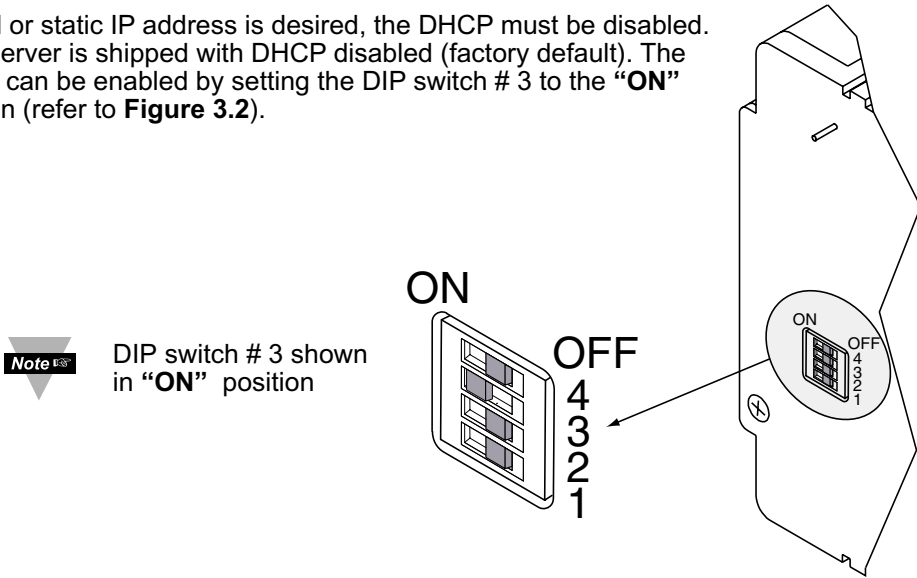

Figure 3.2 DIP Switch on the Bottom Side of iServer

3.4 DNS

DNS, Domain Name System enables individual computers and devices to be recognized over a network based on a specific name instead of an IP address. For example, instead of having to use **http://128.100.101.254** (IP address), you would use only **http://eis03ec** or any eight character name stored as Host Name under Access Control menu in the iServer Home Page. The default DNS name for an iServer is "eis" followed by the last four digits of the MAC address of that particular iServer.

Note:

1. It is very important to communicate with the network administrator in order to understand the DHCP and its existing configurations on the host server, before enabling the DHCP on the iServer.
2. The iServers are shipped with a default static IP address of **128.100.101.254** and Subnet Mask of **255.255.0.0**.
3. On Novell networks or Windows 2000 where the DCHP is an updated function of DNS this feature may be beneficial since a particular name can be assigned eliminating the need for the IP address, as described in **Section 3.4**.

3.5 IP Address

Every active device connected to the TCP/IP network must have a unique IP address. This IP address is used to build a connection to the iServer's serial port. Every computer using TCP/IP should have a unique 32-bit address. It is divided into two portions, the network ID and the host ID. For instance, every computer on the same network uses the same network ID. At the same time, all of them have a different host ID. For more details about the IP address see **Appendix B**.

3.5.1 Default IP Address

The iServer is shipped with a default IP address set to **128.100.101.254** and Subnet Mask of **255.255.0.0**. If you are going to use a Web browser or Telnet program to access the iServer using its default IP address, make sure that the PC from which you're establishing the connection has an IP address that is in the same range as the iServer's IP address (**128.100.x.x**, where **x** can be any number from 1 to 254. Note that your PC's IP address cannot be the same as the iServer's IP address). You also need to make sure that your PC's Subnet Mask is **255.255.0.0**. This is a good way to access the iServer over the network and make any configuration changes needed. If the factory default address is already in use on your network, use an Ethernet crossover cable between your computer and the iServer and modify the IP address or any other settings within the iServer.

3.6 Port Number

All TCP connections are defined by the IP address and a port number. A port number is an internal address that provides an interface between an application running on your computer and the network through the TCP/IP protocol.

There are three default TCP socket port numbers assigned to the iServer:

1. Port (socket) number 1000 when using HTTPGET program.
2. Port (socket) number 2000 when trying to access your serial device connected to the serial port of the iServer.
3. Port (socket) number 2002 when trying to access the iServer itself for reading or changing the settings. This can be done using Telnet application.

Example: C:\>Telnet 128.100.101.254 2002

PART 4 OPERATIONS

This iServer can be used and configured in several ways, depending on user's preference and network setup. It can be used in Telnet simulation mode where it emulates serial communication operation over a network cable or directly from a Web browser, like Netscape or Internet Explorer.

If DHCP and DNS servers are used, the connection is very simple, you do not need to worry about IP address, MAC address, or network conflicts, all of these issues are solved for you by your network DHCP and DNS server. All that is left for you to do, is to use a straight/normal network cable to connect the device to a hub and power it up. Then you can go to your computer that is connected over the same network and from the MS-DOS Prompt window type "**ping eisxxxx**" followed by the last four digits from the MAC address located on the side or back of the device.

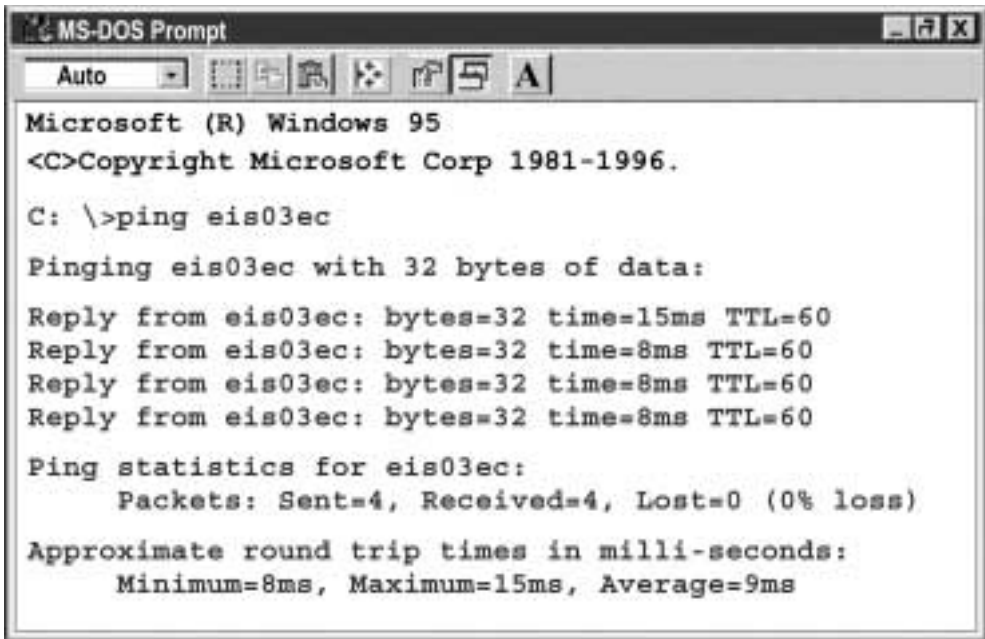

```
MS-DOS Prompt
Auto
Microsoft (R) Windows 95
<C>Copyright Microsoft Corp 1981-1996.
C: \>ping eis03ec
Pinging eis03ec with 32 bytes of data:
Reply from eis03ec: bytes=32 time=15ms TTL=60
Reply from eis03ec: bytes=32 time=8ms TTL=60
Reply from eis03ec: bytes=32 time=8ms TTL=60
Reply from eis03ec: bytes=32 time=8ms TTL=60
Ping statistics for eis03ec:
    Packets: Sent=4, Received=4, Lost=0 (0% loss)
Approximate round trip times in milli-seconds:
    Minimum=8ms, Maximum=15ms, Average=9ms
```

Figure 4.1 Pinging eis03ec MS-DOS Prompt

This proves that the connection is proper and you can get into configuration or run mode using the Telnet or Web browser.

4.1 Setup and Operation Using the iServer Web Page

- a) Start your web browser.
- b) From the browser you type **http://eisxxxx** using the last four-digits from the MAC address label located on the device if DHCP and DNS are used. If a static IP address is used, then simply type **http://x.x.x.x**, where **x.x.x.x** is the iServer's IP address.
- c) The Home Page, shown below, will be displayed.



Figure 4.2 Device Type Menu

- d) From the drop-down window you can select the type of device connected (i-Server, iDRN, iDRX, i-Series, INFB, or iLD) then press Update to get to the Home Page.

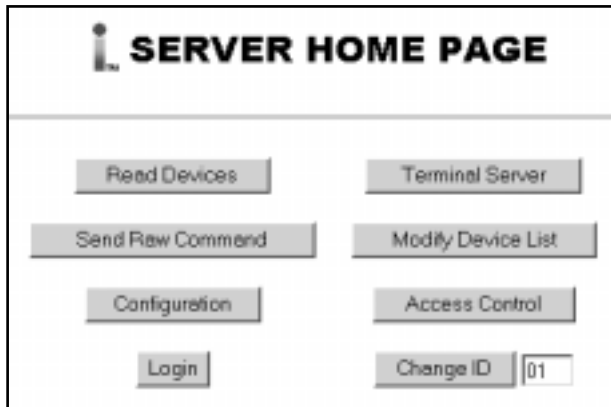

Figure 4.3 iServer Home Page Menu



In order to access certain menu items of the Home Page, users may be prompted with passwords. More details given in later sections.

4.1.1 Read Devices

- Read variables from up to eight different devices.

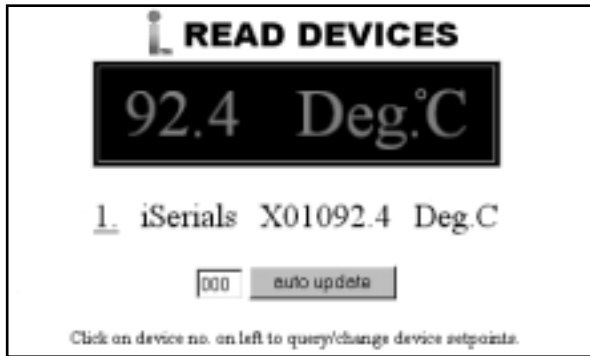

Figure 4.4 Read Devices Menu

- Read up to eight variables from the same device.
- Manually or automatically update readings from your devices. Set time interval for Auto Update.
- Read and write the setpoint values to the device.

Note

Changing Device Setup helps you to see eight different variables or devices by "Check" box.

Note

If access to the menu item is restricted, the user will be prompted for a password. In order to proceed to the "Device Setpoints" submenu, the user should enter the correct password for access Login (default password is **12345678**) or access Admin (default password is **00000000**).

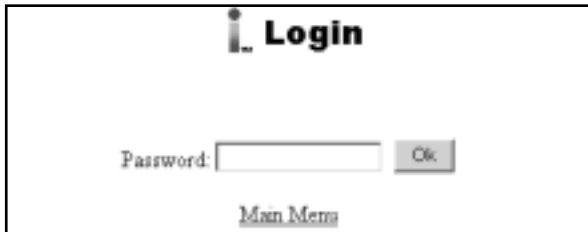

Figure 4.5 Login Password

4.1.2 Send Raw Command

- Send single command and receive response.

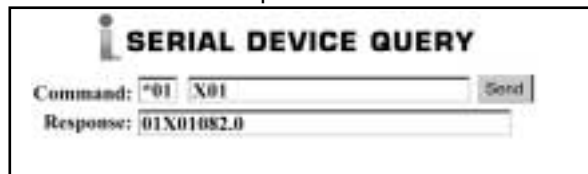

Figure 4.6 Serial Device Query Menu

4.1.3 Modify Device List Entry

- Up to four different devices or parameters can be modified.

Note Device Address or ID is in Hex format. See **Appendix D** for conversion.

DEVICE SETUP

No.	Check	Device Name	Address	Reading	SP1	SP2	SP3	SP4	Display Units	Display Format
1	<input checked="" type="checkbox"/>	iSeries	*01	X01	R01	R01	R01	R01	Deg C	decimal
2	<input type="checkbox"/>	ABCDEFGH	*01	X01	R01	R01	R01	R01	ABCDEFGH	raw
3	<input type="checkbox"/>	ABCDEFGH	*01	X01	R01	R01	R01	R01	ABCDEFGH	raw
4	<input type="checkbox"/>	ABCDEFGH	*01	X01	R01	R01	R01	R01	ABCDEFGH	raw
5	<input type="checkbox"/>	ABCDEFGH	*01	X01	R01	R01	R01	R01	ABCDEFGH	raw
6	<input type="checkbox"/>	ABCDEFGH	*01	X01	R01	R01	R01	R01	ABCDEFGH	raw
7	<input type="checkbox"/>	ABCDEFGH	*01	X01	R01	R01	R01	R01	ABCDEFGH	raw
8	<input type="checkbox"/>	ABCDEFGH	*01	X01	R01	R01	R01	R01	ABCDEFGH	raw

Update Checked Box

Take Readings

Figure 4.7 Device Setup Menu

- Modify device list or parameters.

MODIFY DEVICE LIST ENTRY

Device No. 1

Device Address:

Device Name:

Reading Command:

SP1 Command:

SP2 Command:

SP3 Command:

SP4 Command:

Display Units:

Display Format:

Update Reset

Cancel

Figure 4.8 Modify Device List Menu

4.1.4 Configuration

- This section explains the Configuration page of the iServer's Web interface.
- When connecting your device to the iServer, the Serial Communications parameters must match, between the iServer and your serial device.

The screenshot shows a web interface titled "CONFIGURATION". Under the "Serial Communication" section, the following settings are visible: Baud Rate (9600), Data Bits (8 bits), Parity (none), Stop Bits (1 bit), Flow Control (None), and Transceiver (RS-232). The "Terminal Server" section shows Server Type (SLAVE), Number of Sockets (0), and Port (2000). The "Remote Access (Tunneling)" section shows Remote Access (disable), Remote Port (2000), and Remote IP Address (0.0.0.0). At the bottom, there are "Save" and "Reset" buttons.

Figure 4.9 Configuration Menu

Baud Rate: The speed on the serial port and can be set from 300 to 115,200 bits/s (default is 9600 bits/s.)

Data Bit: Options are 7 or 8 (default is 8 bits.)

Parity: Options are Odd, Even, and None (default is None.)

Stop Bits: Options are 1 and 2 bits (default is 1 bit.)

Flow Control: Options are Software Flow Control (Xon/Xoff), Hardware Flow Control (CTS/RTS), and None (default is None). The Hardware Flow Control is NOT an option for EIS-2.

Transceiver: The serial port can either be set to RS-232 or two-wire RS-485 (default is RS-232.)

End Char: When the defined Hex character is received on the serial port of the iServer, the iServer will forward the data in the serial buffer to the Ethernet. The End Character is just an indicator and will not be sent as part of the data to Ethernet (default is Hex 0D which is the Carriage Return).

If 00 is entered and the serial connection is RS-232, the iServer will forward the data to the LAN as soon as it receives the data from the serial port (requires NO end character to forward the data).

If 00 is entered and the serial connection is RS-485, the iServer will forward the data to the LAN as soon as either the "Timeout" is expired or the "End Char" is received.

Timeout: The amount of time that the iServer listens to its serial port for the incoming data. This is often used for where the iServer needs to switch between the receive and the transmit pins on the two-wire RS-485 connection. The range is from 100ms to 9999ms (default is 500ms)

Server Type: In most cases the iServer will be acting as a Slave device. Slave option is chosen when a network host needs to connect to the serial port of the iServer (default is Slave)

Number of Sockets: The range is from 0 to 5. If 0 is selected, the Terminal Server feature is disabled. That means that no network connection can be made to the serial port of the iServer. If 1 is selected, only one network connection can be made to the iServer's serial port. Any number more than 1 would allow the network hosts to monitor (read only) the traffic on the iServer's serial port simultaneously, but only one network host would be allowed to read and write (default is 0).

Port: This is the port or socket number for the iServer's serial port. Any number between 500 and 9999 can be defined with the exceptions of 1000 and 2002 which are already used by the iServer for other purposes (default is 2000.)

Remote Access: This option needs to be enabled with the Serial Tunneling which is explained in **Section 4.8**.

4.1.5 Configure Access Control

Allows the network user to set a different access level to the iServer parameters for different groups or individual users, as well as setting the TCP/IP parameters of the iServer.



i ACCESS CONTROL

Login Password:

Admin Password:

Host Name:

MAC Address:

IP Address:

Gateway Address:

Subnet Mask:

Figure 4.10 Access Control Menu

There are 2 different access levels:

1. Admin Password (administrator) allows certain groups and individual users to access and modify "All" iServer menu items without any restrictions. The default password is **00000000**. This password can be up to 16 alphanumeric case-sensitive characters.

4.1.5 Configure Access Control (continued)

2. Login Password (operator) allows certain groups and individual users to access and modify "Read Devices" and "Device Setpoints" menus only. The default password is **12345678**. This password can be up to 16 alphanumeric case-sensitive characters.

3. Device Host Name refers to **Section 3.4**. DNS.



If no passwords are needed, simply leave the password fields blank and save your screen.

4.1.6 Login

Allows the user to access the menu items of the iServer Home page. The default password is **12345678** and is changable, if desired.

A screenshot of a login menu. At the top center is the iServer logo (a stylized 'i' with a dot) followed by the word "Login" in a large, bold, sans-serif font. Below the logo is a text label "Password:" followed by a rectangular input field. To the right of the input field is a rectangular button labeled "Ok". Below the input field and button is the text "Main Menu".

Figure 4.11 Login Menu

4.1.7 Change ID

Allows the user to access devices with different addresses residing on RS485, or different variables from same device on communication interface.

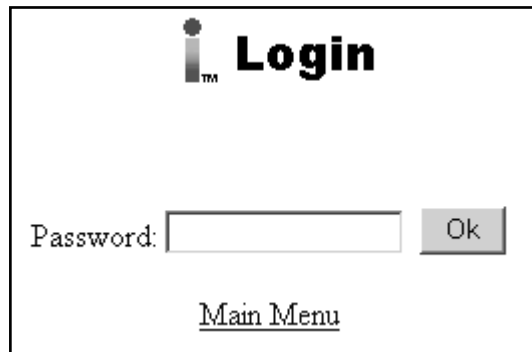

Figure 4.12 Change ID Menu

ID number relates to the Device or Variable No. Refer to Device Setup **Figure 4.7**.

4.2 Setting a New IP Address using the Serial Port

Once you know the IP address that you need to put on your iServer you can use a serial connection (Terminal Emulation) to assign the IP address to the iServer.

Setting the IP address over the serial port requires a crossed-over (null modem) serial cable and Hyper Terminal or any Serial Communication environment. When all the connections are done, change the DIP switch #1 to "ON" position (**Figure 4.14**) and press the Reset button or reset the power on the iServer. The Hyper Terminal screen will acknowledge your connection by asking for the command.

Type "IP=xxx.xxx.xxx.xxx" and press Enter. The screen will acknowledge that your command was executed. Then type **q** and press Enter (**Figure 4.13**) You can now change the DIP switch #1 back to the "OFF" position and reset the power on the iServer.

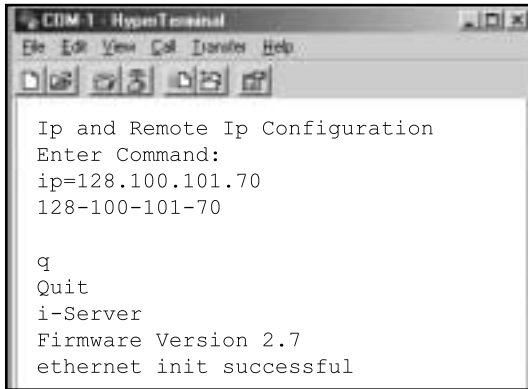

Figure 4.13 Setting the IP address via the Serial Port

Note

You need to make sure to setup the following parameters on your terminal emulation program (i.e. Hyper Terminal)

Baud Rate	- 9600 b/s
Data Bit	- 8 bits
Parity	- None
Stop Bit	- 1 bit
Flow Control	- None
Local Echo	- Enable
Line Feeds	- Enable

Note

DIP switch # 1 shown in "ON" position

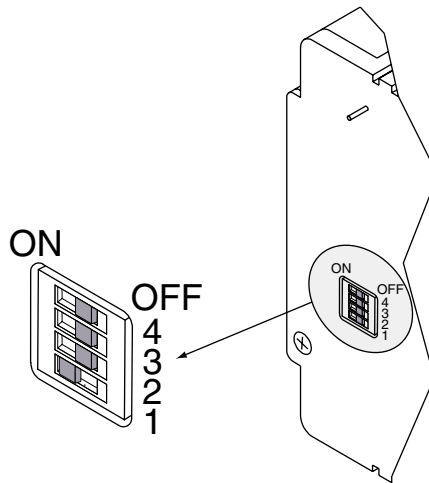
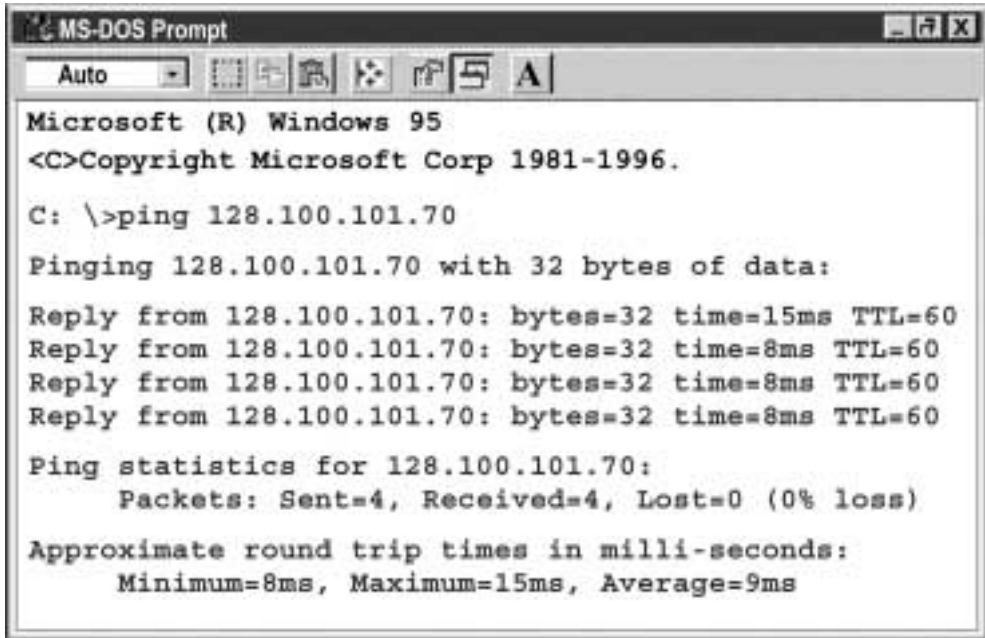

Figure 4.14 DIP switch #1 shown in "ON" position

4.2 Setting a New IP Address using the Serial Port (continued)

All that is left for you to do, is to use a straight/normal network cable to connect the iServer to an Ethernet hub and power it up. Then you can go to your computer that is connected to the same network and from the MS-DOS-Prompt window type "**ping 128.100.101.70**" where 128.100.101.70 is the new IP address for the iServer.



```
MS-DOS Prompt
Auto
Microsoft (R) Windows 95
<C>Copyright Microsoft Corp 1981-1996.
C: \>ping 128.100.101.70
Pinging 128.100.101.70 with 32 bytes of data:
Reply from 128.100.101.70: bytes=32 time=15ms TTL=60
Reply from 128.100.101.70: bytes=32 time=8ms TTL=60
Reply from 128.100.101.70: bytes=32 time=8ms TTL=60
Reply from 128.100.101.70: bytes=32 time=8ms TTL=60
Ping statistics for 128.100.101.70:
    Packets: Sent=4, Received=4, Lost=0 (0% loss)
Approximate round trip times in milli-seconds:
    Minimum=8ms, Maximum=15ms, Average=9ms
```

Figure 4.15 Pinging 128.100.101.70 from the MS-DOS Prompt

This proves that the connection is proper and you can access the iServer using the Telnet or Web browser.

4.3 Setting a New IP Address over the Network

The iServer is shipped with a default IP address of **128.100.101.254** and Subnet Mask of **255.255.0.0**. You can configure your PC's Network connection with an IP address that is in the same range as the iServer's IP address (**128.100.x.x**) and connect to the iServer using a crossover network cable between your PC and the iServer.

With this completed, you can go to the DOS-Prompt and ping 128.100.101.254. If you receive responses back (**Figure 4.15**), you can go to the Web browser and type in **http://128.100.101.254** and it will take you to the Device Type page and then to the Home Page.

Select Access Control button, you'll be asked for the password. First default Login password is "**12345678**" and the Admin password is "**00000000**", then you should be on the administrator setup page where you can simply type in the desired Static IP address, and click Save.



i ACCESS CONTROL

Login Password:

Admin Password:

Host Name:

MAC Address: 00:03:34:00:06:D9

IP Address:

Gateway Address:

Subnet Mask

Figure 4.16 Access Control Menu



For the IP address to take effect the iServer needs to be turned OFF/ON or press the Reset button.

Once all of this is done, you can connect the iServer to an Ethernet hub using a straight through cable, power it up, and follow the ping routine mentioned in the previous section.

4.4 Terminal Server Function

It is used to provide dedicated connectivity between computers and serial devices through the iServer over the Ethernet, without dedicated wiring. The typical Internet protocol consists of a request and a replay to that request. In this situation the server is the Host that generates the request and receives the replay from the device, that gets forwarded to the appropriate party on the network. But there are specific applications where a message is generated by the device, and the server is simply passing the data to the appropriate party on the network, in this situation the server acts as Slave. Examples are the Attendance Time Clocks, Bar Code Readers, remote Displays or Electronic signboards, etc.

For the iServer to pass the data back and forth between its Serial and Ethernet interfaces, the Terminal Server option needs to be configured as follows (**Figure 4.17**):

1. Set the Server Type to Slave
2. Set the Number of Sockets to 1.
3. Set the Port or Socket number to any number from 599 - 9999, except numbers 1000 and 2002.
4. Press the Save button to store the new settings.

From your application software on the host machine, you can now point to the IP address of the iServer and the assigned port number to establish a TCP connection to your serial device connected to the serial port of the iServer.

The screenshot shows a configuration menu with the following sections and settings:

- Serial Communication**
 - Baud Rate: 9600
 - Data Bits: 8 bits
 - Parity: none
 - Stop Bits: 1 bit
 - Flow Control: None
 - Transceiver: RS-232
 - End Char(ASCII Hex): 000D
 - Timeout: 0500 msec(Minimal 100ms)
- Terminal Server**
 - Server Type: SLAVE
 - Number of Sockets: 1
 - Port: 2000
- Remote Access(Tunneling)**
 - Remote Access: disable
 - Remote Port: 2000
 - Remote IP Address: 00.0.0

Figure 4.17 Terminal Server Configuration

Note

If DIP switch #4 is “ON”, Terminal Server function is always enabled, regardless of the firmware configuration. By default, this DIP switch is set to “OFF” position. You have the option to enable the Terminal Server feature either through the firmware or the DIP switch #4.

4.5 Telnet Setup

Telnet stands for Telecommunications Network, is a protocol that provides a way for users (or clients) to connect to computers (or servers) on a network, whether in the next building or across the other side of the world.

You can open a Telnet session using Tera Term Pro (can be download from <http://download.cnet.com/downloads/0-10062-100-890547.html>.) Windows Operating Systems include Telnet program as well. Once the Telnet mechanism is decided we can open a session by simply typing the IP address of the iServer, and setting the Port on 2002 for logging into the iServer Configuration page or 2000 for accessing the serial device connected to the iServer's serial port.



Figure 4.18 Tera Term Telnet Connection Screen

```
P
                                     Configuration
                                     Firmware Version 2.7

BD = 9600 (5)
PT = none (0)
ST = 1 bit (0)
DT = 8 bits (1)
MD = RS-232 (0)
TO = 0500
TT = SLAVE (1)
TN = 0
HN = eis06d9
IP = 128.100.101.254
LP = 12345678
SP = 00000000
TP = iServer
RE = disable (1)
RI = 0.0.0.0
RP = 2000
GW = 0.0.0.0
SM = 255.255.0.0
EC = 0D
PP = 2000
FC = None (0)
MAC = 00:03:34:00:06:D9
```

Figure 4.19 Telnet Setup - iServer Configuration Page



The default password for Telnet Login is 00000000 and can be changed if desired. Telnet works only in RS-232 mode

4.5 Telnet Setup (continued)

In the Configuration mode you can make any changes just like you would do using the Web Browser. After connected to the iServer, the user can use the following commands to read, modify, and get help from the iServer console.

- ? Following with a return character, the console will show all the commands and options (**Figure 4.20**).
- p Following with a return character, the console will show the iServer configurations (**Figure 4.19**).
- s Is the configuration command, used to set a new setting (see the example in **Figure 4.20**)
- r This command is used to read the status of the digital I/O signals (0 is low and 1 is high)
 - Example: r DCD response will be DCD (DSR)=0
 - r DTR response will be DTR=0
- w This command is used to change the status of the digital I/O signals (applies only to the outgoing signals, DTR and RTS)
 - Example : w RTS=1 means raise the RTS
 - w DTR=0 means lower the DTR

```
Login Password:00000000

Login Successful
?
  iServer Configuration Command:

s -[cc]pppppp [-[cc]ppppp]..

cc description pppppp

BD BaudRate          0-300,1-600,2-1200,3-2400,4-4800,5-9600,6-19200,
                        7-38400, 8-57600, 9-115200
PT Parity             0-none,1-Odd,2-even
ST StopBits          0-1bits,1-2bits
DT DataBits          0-7bits,1-8bits
FC FlowControl       0-none,1-XON/XOFF,2-Hardware
MD Mode              0-RS232, 1-RS485
TO TimeOut           xxxx ms Rang range 100-9999
TT TerminalType      0-Host, 1-Slave
TN TerminalNumber    0-5
PP TerminalPort      XXXX 500-9999 but 1000 and 2002
HN HostName          XXXXXXXX maxim 8 characters
IP Static IP         XXX.XXX.XXX.XXX
LP Login Password    XXXXXX maxim 16 characters
SP Admin Password    XXXXXX maxim 16 characters
TP Device Type       0-iServer,1-iDRN,2-iDRX,3-iSeries,4-iNFB,5-iLD
RE Remote Enable     0-Enable, 1-Disable
RI Remote IP         XXX.XXX.XXX.XXX
RP Remote Port       XXXX 500-9999 but 1000 and 2002
GW Gateway           XXX.XXX.XXX.XXX
SM Subnet Mask       XXX.XXX.XXX.XXX
EC End Char          XX represents the Hex Num. of ASCII. i.e 0D means CR
                        (Carrige Return)

Example:
To configure Baudrate 9600, 1 stop bit, Odd Parity, and RS232 mode.
s -BD5 -PT1 -ST1 -MD0
```

Figure 4.20 Telnet Setup - iServer Help Page

4.6 HTTPGET Program

You can setup and read the information from the iServer by using the HTTPGET program. The following program can be used to read data from the embedded server firmware by using TCP port **1000**. The command string sends to this TCP port, then it reads back the response from the same port. Whatever you write to the port goes to the serial port unmodified. Any response from the serial port can be read back from the same socket.

The Httpget.exe file is used to setup and read information from the iServer. This file will be automatically installed when you run any iServer related software available on our website and CD.

Example to use the "**Httpget**" program:

1. Create a directory **C:\iServer\Httpget**.
2. Copy httpget.exe and readme_features.doc files to this directory.
3. Make sure that you are in this directory and then enter the following test program:

```
C:\iServer\Httpget\httpget -r -S "*01X01\r" 128.100.101.254:1000
```

where:

"-r -S" are switches before the command string

"01" is device address (in hex format) for RS485 communication interface (skip for RS232)

"X01" read measurement data value (iSeries protocol)

"\r" calls out a CR

"128.100.101.254" is an IP address

"1000" is a socket port number

Respond:

```
01X01074.3
```

where:

"01X01" is Echo command

"074.3" is a display reading of the 4-digit device



In the example above the 4-digit iSeries controller has been connected to the serial communication port of iServer.

4.7 ARP Protocol

ARP is the Internet layer protocol responsible for determining the MAC (hardware) address that corresponds to a particular IP address. The ARP command allows the user to view the current contents of the ARP cache of the local computer (residing on the same network) or remote computer (residing on the different network) through a router. Microsoft includes the ARP.EXE utility for viewing and modifying the ARP cache with its Windows products. The following ARP commands can be used to view cache entries:

- **arp -a** → Use this command to view all ARP cache entries.
- **arp -a** plus **IP address** → Use this command to view ARP cache entries associated with one particular interface on a network with multiple adapters.
- **arp -g** → Same as arp -a.
- **arp -N** → Use this command to display ARP entries for specific network interface.
- **arp -s** plus **IP address** plus **Physical address** → Use this command to manually add a permanent static entry to the ARP cache.
- **arp -d** → Use this command to manually delete a static entry.

Note

Ping the destination computer using IP address first before using the arp -a command.

The following window shows examples of arp commands and responses.

- Your computer has an IP address of **128.100.101.118**
- The destination computer has an IP address of **128.100.101.96**

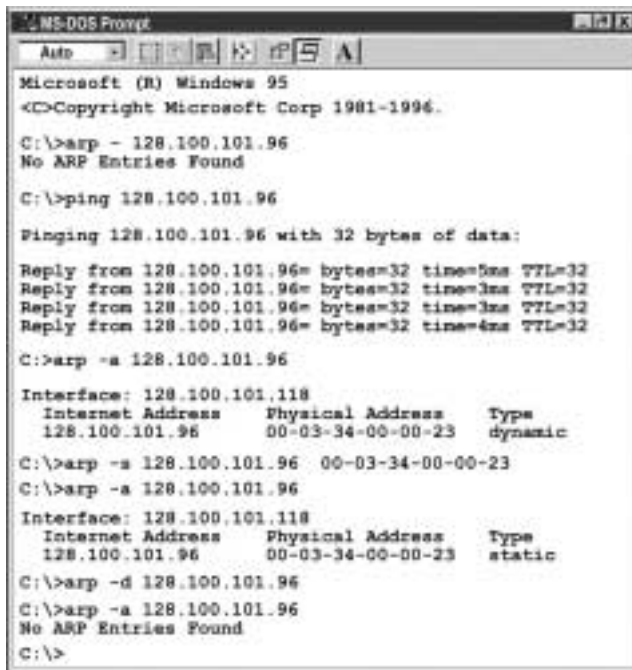

```
Microsoft (R) Windows 95
<C>Copyright Microsoft Corp 1981-1996.

C:\>arp - 128.100.101.96
No ARP Entries Found

C:\>ping 128.100.101.96

Pinging 128.100.101.96 with 32 bytes of data:

Reply from 128.100.101.96= bytes=32 time=5ms TTL=32
Reply from 128.100.101.96= bytes=32 time=3ms TTL=32
Reply from 128.100.101.96= bytes=32 time=3ms TTL=32
Reply from 128.100.101.96= bytes=32 time=4ms TTL=32

C:\>arp -a 128.100.101.96

Interface: 128.100.101.118
Internet Address      Physical Address      Type
128.100.101.96        00-03-34-00-00-23    dynamic

C:\>arp -s 128.100.101.96 00-03-34-00-00-23
C:\>arp -a 128.100.101.96

Interface: 128.100.101.118
Internet Address      Physical Address      Type
128.100.101.96        00-03-34-00-00-23    static

C:\>arp -d 128.100.101.96
C:\>arp -a 128.100.101.96
No ARP Entries Found

C:\>
```

Figure 4.21 ARP Commands and Responses

4.8 Remote Access (Tunneling)

To "tunnel", in this context, is to transmit data between two points through a private conduit on a shared or public network. The network could be an Ethernet LAN, a WAN, or the Internet. The iServer allows for a connection between a serial device and a PC, or between two serial devices, using an existing network rather than dedicated wiring.

Today, there are number of serial devices like sensors, gauges, PLCs, card readers, security alarms, barcode scanners, data loggers, video cameras, ATM machines, time & attendance terminals, medical lab equipments, electronic signboards, and many others that are directly connected to PCs via their serial ports. These devices can be attached to shared Ethernet networks (TCP/IP protocol) and get accessed, controlled, and managed remotely using the iServer products. Any two iServer's can talk to each other over the Ethernet LAN, WAN, and Internet using TCP/IP protocol. Therefore, the connected serial devices to iServer's can also communicate with each other back and forth over these networks. This characteristic is called Tunneling and it's illustrated in **Figures 4.22** and **4.23**.

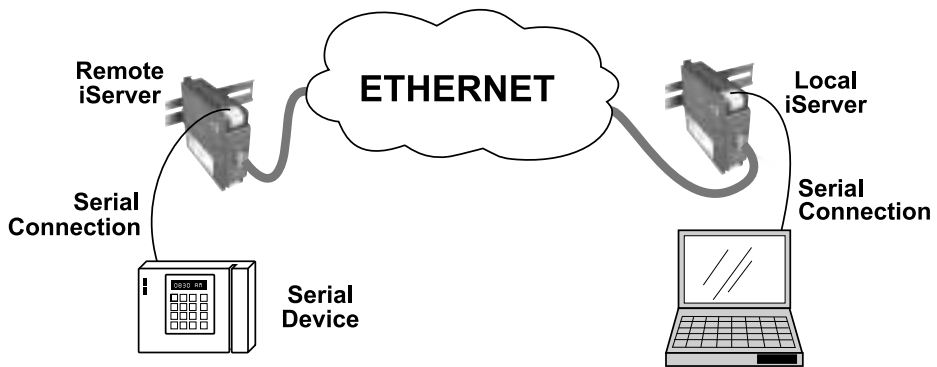

Figure 4.22 PC-to-Device Communication

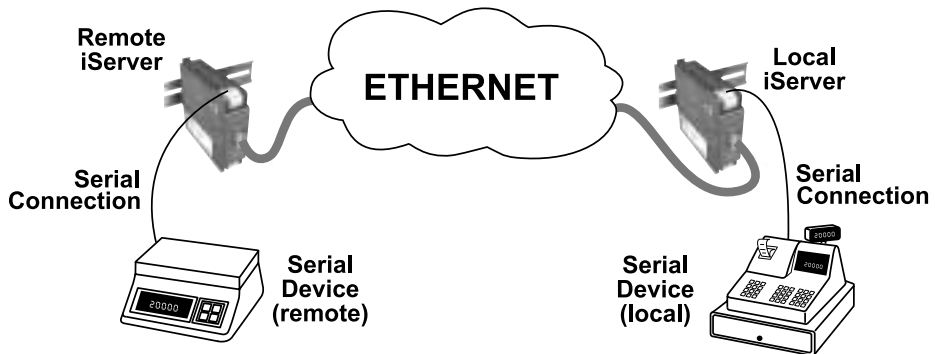

Figure 4.23 Device-to-Device Communication

In order to use this Tunneling feature, some settings are required within the local and remote iServer's.

4.8.1 Remote iServer

1. A static IP address should be assigned to the iServer. This means that the DHCP must be disabled. Refer to the DHCP section for details.
2. Use a browser to access iServer's WEB server. Simply type the iServer's IP address at the browser's URL location (i.e. <http://128.100.101.84>).
3. Click on Update button.
4. Click on Configuration button and enter the password (the default password is 12345678).
5. Click on Configuration button once again and now you're on the configuration page.
6. Under Terminal Server section, set Number of Sockets to "1" and Server Type to "Slave".
7. Click on Save button for the changes to take place.
8. Make sure that the serial connection between the remote iServer and the serial device is valid and the serial settings like baud rate, stop bit and parity are configured correctly.

Terminal Server

Server Type: Number of Sockets: Port:

Remote Access (Tunneling)

Remote Access: Remote Port:

Remote IP Address:

Figure 4.24 Configuration Menu - Remote iServer

4.8.2 Local iServer

1. An IP address should be assigned to the iServer either statically or using a DHCP server.
2. Use a browser to access iServer's WEB server. Simply type the iServer's IP address at the browser's URL location (i.e. <http://128.100.101.254>).
3. Click on Update button.
4. Click on Configuration button and enter the password (the default password is 12345678).
5. Click on Configuration button once again and now you're on the configuration page.
6. Under Terminal Server section, set Number of Sockets to "0".
7. Under Remote Access section,
 - a. Set the Remote Access to "enable".
 - b. Use the default Remote Port **2000**.
 - c. Enter the IP address of the remote iServer (i.e. **128.100.101.84**).
8. Click on Save button for the changes to take place.
9. Make sure that the serial connection between the local iServer and the serial device is valid and the serial settings like baud rate, stop bit, parity, etc. are configured correctly.

At this point, reset the power, first on the remote and then the local iServer and initialize the local serial device to send or request data.

Terminal Server

Server Type: Number of Sockets: Port:

Remote Access (Tunneling)

Remote Access: Remote Port:

Remote IP Address:

Figure 4.25 Configuration Menu - Local iServer

4.9 Mail Notifier Software

For complete information of how to use the Mail Notifier software, click on the Help menu of the main window.

The Mail Notifier software utilizes E-Mail notifications of alarm conditions of the devices having either embedded iServer board or connected via the stand alone iServer units, which reformats RS232/485 bus traffic into Ethernet packets. Hence users/operators can be notified automatically of alarm conditions monitored via internet connections throughout the world. By use of the E-Mail forwarding of alarm conditions, alarm conditions can be monitored on a network isolated from the internet and forwarded to connections on the Internet.

The Mail Notifier utility operates under Windows 95, 98, NT 4.0, and NT 2000 in conjunction with existing E-Mail that supports the MAPI messaging interface. If MS Outlook has been loaded, the MAPI support should be available.

4.9.1 Installation

The Mail Notifier must be loaded on a computer running Microsoft Windows (versions specified earlier) and with a MAPI client software. Network access must be available between this computer and the iServer. Network access must also be available from this computer to the appropriate E-Mail server and from the E-Mail server to the recipient's E-Mail server.



Figure 4.26 iServer Mail Notifier Main Window

4.9.2 Program Options Setup and Configuration

Note

Complete program setup requires:

- Entering a recipient for the E-Mail
- Specifying connection details to MAPI services.
- Defining alarms for devices, and selecting how and when the E-Mail will be active.



Figure 4.27 iServer Mail Notifier Profile Setup

The E-Mail User tab provides fields to define the name/profile for the Mail Notifier to utilize when E-Mail is sent.

Follow the steps below to set profile in Microsoft Exchange (5.0.1458.47)

1. Start Microsoft Exchange.
2. From Menu bar select tools, options.
3. It will open to the General tab.
4. On the General tab there is the "When starting Microsoft Exchange" options.
5. The profile name is specified under the "Always use this profile" option button.
6. On the Mail Notifier, go to View, Options.
7. From the options dialog, go to the E-mail User tab.
8. Set the Name/Profile to the profile name obtained in Step 5
9. Make sure that the E-Mail Access option is set to MS Outlook. (This is used to prevent input of a password -- which isn't going to be used with Microsoft Exchange)

The Send To tab contains a field to specify an E-mail address to which alarm notifications will be sent. Only one entry is permitted, but with some E-Mail packages, the entry can represent a group of users with different E-Mail addresses.

4.9.3 Device Setting and Configuration

Device setup requires:

- Entering the IP address for iServer device (for example 128.100.101.98).
- Specifying Socket number (1000 for iServer).
- Defining RS485 Unit # serial interface address (1 to 199). Enter "0" for RS232 interface.
- Entering Reading command. Normally set to X01 to obtain reading from the devices.
- Defining the Alarm setup (High/Low, High value, or Low value).
- Specifying Pause Interval. It determines how many seconds each subsequent alarm notification will be sent.
- Determining Monitor interval. It establishes the interval or time resolution in seconds for which readings will be obtained from the device.

The screenshot shows a dialog box titled "Alarm Editor" with a close button (X) in the top right corner. The dialog is divided into two main sections: "device info (2 of 2)" and "Alarm Configuration".

device info (2 of 2)

Server IP Address	128.100.101.98
Socket Number	1000
RS485 Unit #	1
Description	iSeries Controller
Src ID	Dev 2
Reading Cmd	X01

On the right side of the "device info" section, there are four buttons: "OK", "Cancel", "Help", and "Add". Below the "Add" button is a "Del" button.

Alarm Configuration

Alarm Type	Alarm Low	Info Message	Alarm triggered
Alarm High	70	Pause Interval	60
Alarm Low	100	Monitor Interval	5

Figure 4.28 iServer Mail Notifier Device Setting

PART 5 SPECIFICATIONS

SERIAL INTERFACE

Interface:

RS-232, RS-422 or RS-485 (2 wire)

Connector:

Screw Terminal Block (EIS-2 model)

RJ45 (EIS-2-RJ model)

Data Rates:

300 to 115200 bps

Characters:

7 or 8 data bits

Parity:

odd, even, or none

Stop bits:

1 or 2

Flow Control:

Software (Xon/Xoff)

Hardware (CTS/RTS) only with EIS-2-RJ

NETWORK INTERFACE

Interface:

Ethernet 10 Base-T

Connector:

RJ45

Protocols:

ARP, ICMP, TCP/IP, DNS, DHCP,
Telnet and HTTP

Indicators (LED):

Network Activity/COL (red),

Network Link/ON (green),

TX-Transmit (yellow),

RX-Receive (green),

PROCESSOR

CPU:

Enhanced 8051, 22 MHz

Memory:

16 Kbyte SRAM, 512 Kbyte Flash

Management:

Serial Login, Telnet Login,

Internal Web Server

INTERNAL WEB SERVER

Uses: Dynamic web pages and Java applets (256 Kbyte capacity)

ENVIRONMENTAL

Operating Temperature:

0 to 70°C (32 to 158°F)

Storage Temperature:

-40 to 125°C (-40 to 257°F)

Power Input

10-32 Vdc

Consumption:

2 W max

GENERAL

Agency Approvals

FCC-B, C/UL, CE

Software

Firmware upgradeable. Compatible with Windows 9x / ME / NT / 2000 / XP software and related utilities

PACKAGING

Material:

Plastic case with DIN Rail mount

Dimensions:

90.2H x 25.1W x 115.0 D mm
(3.54 x 0.99 x 4.53 in)

Weight:

0.113 kg (0.25 lbs.)

**PART 6
FACTORY PRESET VALUES**

PRESET PARAMETERS	FACTORY DEFAULTS
Network Interface:	
IP Address	128.100.101.254
Gateway Address	0.0.0.0
Subnet Mask	255.255.0.0
Device Host Name	eis and the last 4 digits from the MAC address
Login Password	12345678
Admin Password	00000000
DHCP	Disabled
Serial Interface:	
Communication Protocol	RS-232
Flow Control	None
Baud Rate	9600
Parity	None
Stop Bit	1 bit
Data Bit	8 bits
Timeout	500 msec
End Character	0D (Hex) (Carridge Return)
Terminal Server:	
Server Type	Slave
Number of Sockets	0
Port #	2000
Server Mode	Disable
Remote Access (Tunneling):	
Remote Access	Disable
Remote Port	2000
Remote IP Address	0.0.0.0

User of this manual should be familiar with following definitions:

ARP (Address Resolution Protocol) is a protocol for mapping an Internet Protocol address (IP address) to a physical machine address that is recognized in the local network. For example, the IP address in use today is an address that is 32-bits long. In an Ethernet local area network, however, addresses for attached devices are 48-bits long. (The physical machine address is also known as a Media Access Control or MAC address.) A table, usually called the ARP cache, is used to maintain a correlation between each MAC address and its corresponding IP address. ARP provides the protocol rules for making this correlation and providing address conversion in both directions.

Ethernet is a network protocol defined by the IEEE 802.3 standard. Ethernet-based networks use MAC Address rather than IP Address to exchange data between computers. By using ARP and adding TCP/IP support, Ethernet devices may be connected as part of the Internet. An Ethernet LAN typically uses coaxial cable or special grades of twisted pair wires. The most commonly installed Ethernet systems are called 10BASE-T and provide transmission speeds up to 10 Mbps. Devices are connected to the cable and compete for access using a Carrier Sense Multiple Access with Collision Detection (CSMA/CD) protocol.

IP (Internet Protocol) is the method or protocol by which data is sent from one computer to another on the Internet.

IP address (Internet Protocol address) is a 32-bit number that identifies each sender or receiver of information that is sent in packets across the Internet.

IP Netmask is a 32-bit pattern of bits used to determine which part of the IP address is the network portion and which part is the host portion.

MAC (Media Access Control) Address is your computer's unique hardware number. When you're connected to the Internet from your computer, a correspondence table relates your IP address to your computer's physical (MAC) address on the LAN.

Ping is a utility that tests the network connectivity. It is used to determine if the host is capable of exchanging information with another host.

Port number/Socket number is a way to identify a specific process to which an Internet or other network message is to be forwarded when it arrives at a server. It is a predefined address that serves as a route from the application to the Transport layer or from the Transport layer to the application of the TCP/IP system.

Sockets are a method for communication between a client program and a server program in a network and defined as "the endpoint in a connection." Information transferred across the Internet primarily occurs between sockets.

TCP/IP (Transmission Control Protocol/Internet Protocol) is the basic communication language or protocol of the Internet. When you are set up with direct access to the Internet, your computer is provided with a copy of the TCP/IP program just as every other computer that you may send messages to or get information from also has a copy of TCP/IP. TCP/IP often is used as a general term to indicate generic access to the Internet.

Appendix B

IP Address

An IP address is a unique 32-bit address assigned to a computer and includes:

- A network ID number identifying a network.
- A host ID number identifying a computer on the network.

All IP addresses have been divided into three smaller groups (classes) A, B and C

- **Class A** addresses have 8-bits of network ID and 24-bits of host ID. They can support a large number of hosts, approximately $2^{24} = 16,777,216$ computers per network.

The IP addresses range in binary from 00000001.xxxxxxxx.xxxxxxxx.xxxxxxxx
to 01111111.xxxxxxxx.xxxxxxxx.xxxxxxxx

The IP addresses range in decimal from 1.x.x.x to 127.x.x.x

Class A network ID's support a very large number of hosts.

- **Class B** addresses have 16-bits of network ID and 16-bits of host ID. They can support approximately $2^{16} = 65,536$ computers per network.

The IP addresses range in binary from 10000000 00000000.xxxxxxxx.xxxxxxxx
to 10111111 11111111.xxxxxxxx.xxxxxxxx

The IP addresses range in decimal from 128.0.x.x TO 191.255.xxx.xxx

Class B network ID's support a medium number of hosts.

- **Class C** addresses have 24-bits of network ID and 8-bits of host ID. They can support approximately $2^8 = 256$ computers per network.

The IP addresses range in binary from 11000000.00000000.00000000.xxxxxxxx
to 11011111.11111111.11111111.xxxxxxxx

The IP addresses range in decimal from 192.0.0.xxx to 223.255.255.xxx

Class C network ID's support a small number of hosts.



The rest of the addresses are divided into two classes, D and E.

Class D networks are not assigned to the host. They are used for multicasting.
The address range from 224.x.x.x to 239.x.x.x

Class E networks are experimental or reserved addresses.
The address range from 240.x.x.x to 247.x.x.x

Appendix C

IP Netmask

IP Netmask or Subnet Mask is a 32-bit pattern of ones and zeros used to determine network portion of an IP address from the host portion of the IP address. Subnet mask is a network ID that is created by borrowing bits from host portion of IP address and using them as part of a network ID. The table below shows a default subnet mask for address Classes A, B, and C. Each bit that is set to "1" in the subnet mask corresponds to the bit in the IP address that is to be used as the network ID. Each bit that is set to "0" in the subnet mask corresponds to a bit in the IP address that is to be used as the host ID.

Address Class	Mask Binary Value	Mask Decimal Value or Dotted Notation
Class A	11111111 00000000 00000000 00000000	255.0.0.0
Class B	11111111 11111111 00000000 00000000	255.255.0.0
Class C	11111111 11111111 11111111 00000000	255.255.255.0

If your network requires more network ID's, you can extend the default subnet mask to include additional bits from the host ID. This allows for additional network ID's within the network. The table below shows some examples of subnet masks and bits moved from the hosts ID to create a new subnet.

Mask Dotted Notation	Mask Binary	Mask Bits
Class A		
255.0.0.0 (Default)	11111111 00000000 00000000 00000000	0
255.192.0.0	11111111 11000000 00000000 00000000	2
255.224.0.0	11111111 11100000 00000000 00000000	3
255.240.0.0	11111111 11110000 00000000 00000000	4
255.248.0.0	11111111 11111000 00000000 00000000	5
255.252.0.0	11111111 11111100 00000000 00000000	6
255.254.0.0	11111111 11111110 00000000 00000000	7
255.255.0.0	11111111 11111111 00000000 00000000	8
255.255.128.0	11111111 11111111 10000000 00000000	9
255.255.192.0.0	11111111 11111111 11000000 00000000	10
.....
255.255.255.252	11111111 11111111 11111111 11111100	22
Class B		
255.255.0.0 (Default)	11111111 11111111 00000000 00000000	0
255.255.192.0	11111111 11111111 11000000 00000000	2
.....
255.255.255.252	11111111 11111111 11111111 11111100	14
Class C		
255.255.255.0 (Default)	11111111 11111111 11111111 00000000	0
255.255.255.192	11111111 11111111 11111111 11000000	2
.....
255.255.255.254	11111111 11111111 11111111 11111100	6

To determine the number of valid hosts ID's remaining after subnetting, use the following equation: $2^n - 2$, where n is the number of octet digits left after the subnet mask.

Appendix D

ASCII Chart

ASCII Char	Dec	Hex	Binary No Parity	ASCII Char	Dec	Hex	Binary No parity
NUL	00	00	00000000	@	64	40	01000000
SOH	01	01	00000001	A	65	41	01000000
STX	02	02	00000010	B	66	42	01000010
ETX	03	03	00000011	C	67	43	01000011
EOT	04	04	00000100	D	68	44	01000100
ENQ	05	05	00000101	E	69	45	01000101
ACK	06	06	00000110	F	70	46	01000110
BEL	07	07	00000111	G	71	47	01000111
BS	08	08	00001000	H	72	48	01001000
HT	09	09	00001001	I	73	49	01001001
LF	10	0A	00001010	J	74	4A	01001010
VT	11	0B	00001011	K	75	4B	01001011
FF	12	0C	00001100	L	76	4C	01001100
CR	13	0D	00001101	M	77	4D	01001101
SO	14	0E	00001110	N	78	4E	01001110
SI	15	0F	00001111	O	79	4F	01001111
DLE	16	10	00010000	P	80	50	01010000
DC1	17	11	00010001	Q	81	51	01010001
DC2	18	12	00010010	R	82	52	01010010
DC3	19	13	00010011	S	83	53	01010011
DC4	20	14	00010100	T	84	54	01010100
NAK	21	15	00010101	U	85	55	01010101
SYN	22	16	00010110	V	86	56	01010110
ETB	23	17	00010111	W	87	57	01010111
CAN	24	18	00011000	X	88	58	01011000
EM	25	19	00011001	Y	89	59	01011001
SUB	26	1A	00011010	Z	90	5A	01011010
ESC	27	1B	00011011	[91	5B	01011011
FS	28	1C	00011100	\	92	5C	01011100
GS	29	1D	00011101]	93	5D	01011101
RS	30	1E	00011110	^	94	5E	01011110
US	31	1F	00011111	_	95	5F	01011111
SP	32	20	00100000	`	96	60	01100000
!	33	21	00100001	a	97	61	01100001
"	34	22	00100010	b	98	62	01100010
#	35	23	00100011	c	99	63	01100011
\$	36	24	00100100	d	100	64	01100100
%	37	25	00100101	e	101	65	01100101
&	38	26	00100110	f	102	66	01100110
'	39	27	00100111	g	103	67	01100111
(40	28	00101000	h	104	68	01101000
)	41	29	00101001	i	105	69	01101001
*	42	2A	00101010	j	106	6A	01101010
+	43	2B	00101011	k	107	6B	01101011
,	44	2C	00101100	l	108	6C	01101100
-	45	2D	00101101	m	109	6D	01101101
.	46	2E	00101110	n	110	6E	01101110

Appendix D

ASCII Chart Continuation

/	47	2F	00101111	o	111	6F	01101111
0	48	30	00110000	p	112	70	01110000
1	49	31	00110001	q	113	71	01110001
2	50	32	00110010	r	114	72	01110010
3	51	33	00110011	s	115	73	01110011
4	52	34	00110100	t	116	74	01110100
5	53	35	00110101	u	117	75	01110101
6	54	36	00110110	v	118	76	01110110
7	55	37	00110111	w	119	77	01110111
8	56	38	00111000	x	120	78	01111000
9	57	39	00111001	y	121	79	01111001
:	58	3A	00111010	z	122	7A	01111010
;	59	3B	00111011	{	123	7B	01111011
<	60	3C	00111100		124	7C	01111100
=	61	3D	00111101	}	125	7D	01111101
>	62	3E	00111110	~	126	7E	01111110
?	63	3F	00111111	DEL	127	7F	01111111

ASCII Control Codes

ASCII Char	Dec	Hex	Ctrl Key Equiv.	Definition	ASCII Char	Dec	Hex	Ctrl Key Equiv.	Definition
NUL	00	00	Ctrl @	Null Character	DC1	17	11	Ctrl Q	Data Control 1 - XON
SOH	01	01	Ctrl A	Start of Header	DC2	18	12	Ctrl R	Data Control 2
STX	02	02	Ctrl B	Start of Text	DC3	19	13	Ctrl S	Data Control 3 - XOFF
ETX	03	03	Ctrl C	End of Text	DC4	20	14	Ctrl T	Data Control 4
EOT	04	04	Ctrl D	End of Transmission	NAK	21	15	Ctrl U	Negative Acknowledge
ENQ	05	05	Ctrl E	Inquiry	SYN	22	16	Ctrl V	Synchronous Idle
ACK	06	06	Ctrl F	Acknowledge	ETB	23	17	Ctrl W	End of Trans Block
BEL	07	07	Ctrl G	Bell	CAN	24	18	Ctrl X	Cancel
BS	08	08	Ctrl H	Back Space	EM	25	19	Ctrl Y	End of Medium
HT	09	09	Ctrl I	Horizontal Tabulation	SUB	26	1A	Ctrl Z	Substitute
LF	10	0A	Ctrl J	Line Feed	ESC	27	1B	Ctrl [Escape
VT	11	0B	Ctrl K	Vertical Tabulation	FS	28	1C	Ctrl \	File Separator
FF	12	0C	Ctrl L	Form Feed	GS	29	1D	Ctrl]	Group Separator
CR	13	0D	Ctrl M	Carriage Return	RS	30	1E	Ctrl	Record Separator
SO	14	0E	Ctrl N	Shift Out	US	31	1F	Ctrl _	Unit Separator
SI	15	0F	Ctrl O	Shift In	SP	32	20		Space
DLE	16	10	Ctrl P	Data Link Escape					

PART 7 APPROVALS INFORMATION

7.1 Electrical Compatibility (EMC)

This device conforms with requirements of EMC Directive 89/336/EEC, amended by 93/68/EEC. This instrument complies with the following EMC Immunity Standards as tested per EN 50082-2, 1995 (Industrial environment)

Phenomena	Test Specification	Basic Standard
Electrostatic Discharge	+/- 4 kV contact discharge +/- 8 kV air discharge	IEC 1000-4-2 Performance Criteria B
Radio Frequency electromagnetic field.	27 - 1000 MHz 10 V/m 80% AM (1 KHz)	IEC 1000-4-3 Performance Criteria A
Radio Frequency electromagnetic field. Pulse modulated.	900 MHz 10 V/m 50% Duty cycle @ 200 Hz	IEC 1000-4-3 Performance Criteria A
Fast Transients	+/- 2 kV (ac mains) +/- 1 kV (dc, signal I/O) 5/50 ns Tr/Th, 5 KHz rep. freq.	IEC 1000-4-4 Performance Criteria B
Radio Frequency conducted	0.15 - 80 MHz 10 V/m 80% AM (1 KHz)	IEC 1000-4-6 Performance Criteria A

This instrument complies with the following EMC Emission Standards as tested per EN 50081-1, 1992 (Residential, Commercial and Light Industrial)

Phenomena	Frequency Range	Limits	Basic Standard
Radiated Emission	30-230 MHz 230-1000 MHz	30 dB μ V/m at 10 m 37 dB μ V/m at 10 m quasi peak	CISPR 22 Class B
Conducted Emission	0.15-0.5 MHz 0.5-5 MHz 5-30 MHz	66-56 dB μ V quasi peak 56 dB μ V quasi peak 60 dB μ V quasi peak	CISPR 22 Class B

Safety

This device conforms with Low Voltage Directive 73/23/EEC, amended by 93/68/EEC. The following LVD requirements have been met to comply with EN 61010-1, 1993 (Electrical equipment for measurement, control and laboratory use).

Pollution Degree 2

Class III Equipment (10-32 Vdc Low Power Option)

7.2 FCC

This device complies with Part 15, Subpart B, Class B of the FCC rules

Warranty/Disclaimer

NEWPORT Electronics, Inc. warrants this unit to be free of defects in materials and workmanship for a period of **one (1) year** from the date of purchase. In addition to NEWPORT's standard warranty period, NEWPORT Electronics will extend the warranty period for **one (1) additional year** if the warranty card enclosed with each instrument is returned to NEWPORT.

If the unit should malfunction, it must be returned to the factory for evaluation. NEWPORT's Customer Service Department will issue an Authorized Return (AR) number immediately upon phone or written request. Upon examination by NEWPORT, if the unit is found to be defective it will be repaired or replaced at no charge. NEWPORT's WARRANTY does not apply to defects resulting from any action of the purchaser, including but not limited to mishandling, improper interfacing, operation outside of design limits, improper repair, or unauthorized modification. This WARRANTY is VOID if the unit shows evidence of having been tampered with or shows evidence of being damaged as a result of excessive corrosion; or current, heat, moisture or vibration; improper specification; misapplication; misuse or other operating conditions outside of NEWPORT's control. Components which wear are not warranted, including but not limited to contact points, fuses, and triacs.

NEWPORT is pleased to offer suggestions on the use of its various products. However, NEWPORT neither assumes responsibility for any omissions or errors nor assumes liability for any damages that result from the use of its products in accordance with information provided by NEWPORT, either verbal or written. NEWPORT warrants only that the parts manufactured by it will be as specified and free of defects. NEWPORT MAKES NO OTHER WARRANTIES OR REPRESENTATIONS OF ANY KIND WHATSOEVER, EXPRESSED OR IMPLIED, EXCEPT THAT OF TITLE, AND ALL IMPLIED WARRANTIES INCLUDING ANY WARRANTY OF MERCHANTABILITY AND FITNESS FOR A PARTICULAR PURPOSE ARE HEREBY DISCLAIMED. LIMITATION OF LIABILITY: The remedies of purchaser set forth herein are exclusive and the total liability of NEWPORT with respect to this order, whether based on contract, warranty, negligence, indemnification, strict liability or otherwise, shall not exceed the purchase price of the component upon which liability is based. In no event shall NEWPORT be liable for consequential, incidental or special damages.

CONDITIONS: Equipment sold by NEWPORT is not intended to be used, nor shall it be used: (1) as a "Basic Component" under 10 CFR 21 (NRC), used in or with any nuclear installation or activity; or (2) in medical applications or used on humans. Should any Product(s) be used in or with any nuclear installation or activity, medical application, or used on humans, or misused in any way, NEWPORT assumes no responsibility as set forth in our basic WARRANTY / DISCLAIMER language, and additionally purchaser will indemnify NEWPORT and hold NEWPORT harmless from any liability or damage whatsoever arising out of the use of the Product(s) in such a manner.

Return Requests/Inquiries

Direct all warranty and repair requests/inquiries to the NEWPORT Customer Service Department. **BEFORE RETURNING ANY PRODUCT(S) TO NEWPORT, PURCHASER MUST OBTAIN AN AUTHORIZED RETURN (AR) NUMBER FROM NEWPORT'S CUSTOMER SERVICE DEPARTMENT (IN ORDER TO AVOID PROCESSING DELAYS).** The assigned AR number should then be marked on the outside of the return package and on any correspondence.

The purchaser is responsible for shipping charges, freight, insurance and proper packaging to prevent breakage in transit.

FOR **WARRANTY** RETURNS, please have the following information available **BEFORE** contacting NEWPORT:

1. P.O. number under which the product was **PURCHASED**,
2. Model and serial number of the product under warranty, and
3. Repair instructions and/or specific problems relative to the product.

FOR **NON-WARRANTY** REPAIRS, consult NEWPORT for current repair charges. Have the following information available **BEFORE** contacting NEWPORT:

1. P.O. number to cover the **COST** of the repair,
2. Model and serial number of product, and
3. Repair instructions and/or specific problems relative to the product.

NEWPORT's policy is to make running changes, not model changes, whenever an improvement is possible. This affords our customers the latest in technology and engineering.

NEWPORT is a registered trademark of NEWPORT Electronics, Inc.

© Copyright 2003 NEWPORT Electronics, Inc. All rights reserved. This document may not be copied, photocopied, reproduced, translated, or reduced to any electronic medium or machine-readable form, in whole or in part, without prior written consent of NEWPORT Electronics, Inc.

For immediate technical or application assistance please call:

1-800-6397678®
1-800-NEWPORT

Newport Electronics, Inc.

2229 South Yale Street • Santa Ana, CA • 92704 • U.S.A.

TEL: (714) 540-4914 • FAX: (203) 968-7311

Toll Free: 1-800-639-7678 • www.newportUS.com • e-mail: info@newportUS.com

ISO 9001 Certified

Newport Technologies, Inc.

976 Bergar • Laval (Quebec) • H7L 5A1 • Canada

TEL: (514) 335-3183 • FAX: (514) 856-6886

Toll Free: 1-800-639-7678 • www.newport.ca • e-mail: info@newport.ca

Newport Electronics, Ltd.

One Omega Drive • River Bend Technology Centre

Northbank, Irlam • Manchester M44 5BD • United Kingdom

Tel: +44 161 777 6611 • FAX: +44 161 777 6622

Toll Free: 0800 488 488 • www.newportuk.co.uk • e-mail: sales@newportuk.co.uk

Newport Electronics B.V.

Postbus 8034 • 1180 LA Amstelveen • The Netherlands

TEL: +31 20 3472121 • FAX: +31 20 6434643

Toll Free: 0800 0993344 • www.newport.nl • e-mail: info@newport.nl

Newport Electronics spol s.r.o.

Frystatska 184, 733 01 Karviná • Czech Republic

TEL: +420 59 6311899 • FAX: +420 59 6311114

Toll Free: 0800-1-66342 • www.newport.cz • e-mail: info@newport.cz

Newport Electronics GmbH

Daimlerstrasse 26 • D-75392 Deckenpfronn • Germany

TEL: 49 7056 9398-0 • FAX: 49 7056 9398-29

Toll Free: 0800 / 6397678 • www.newport.de • e-mail: sales@newport.de

Newport Electronique S.A.R.L.

11, rue Jacques Cartier • 78280 Guyancourt • France

TEL: +33 1 61 37 29 00 • FAX: +33 1 30 57 54 27

Toll Free: 0800 466 342 • www.newport.fr • e-mail: sales@newport.fr

Mexico and Latin America

FAX: 001 (203) 359-7807

En Español: 001 (203) 359-7803

NEWPORTnetSM On-Line Service www.newportUS.com	Internet e-mail info@newportUS.com
--	--



NEWPORT Electronics, Inc.